

50 Hz & 60 Hz ●

CX SERIES

SEMI-HERMETIC COMPACT
SCREW COMPRESSORS

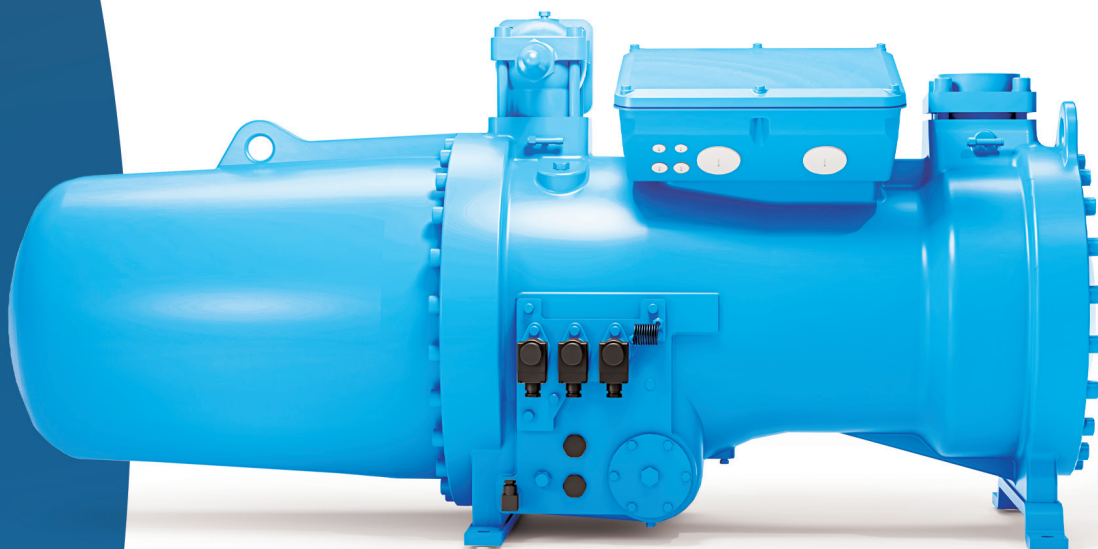

富士豪[®]
FRASCOLD SPA

CX SERIES

**SEMI-HERMETIC COMPACT
SCREW COMPRESSORS**



INDEX

Product information

Features & Benefits

Conformity Declaration

Performance Data FSS3 Software

ATEX Certification

UL Certification

Capacity

Product Range

Model Designation

Information Plate

Standard Equipment and Optional Accessories

Control Protection Device

Capacity regulation

Technical Data

Operating Limits

Technical Drawings and Dimensions

Contact & Subsidiaries



● Product information

SEMI-HERMETIC COMPACT SCREW COMPRESSORS

The **CX series** has been completely designed to grant the maximum efficiency, reliability and flexibility. Based on your necessities they are divided in three configurations: **CX EVO, CX Water and CX Air**.

The **CX Water** is designed for low compression ratio applications, with a range of **3 sizes and 29 models**.

The **CX Air** represent the excellent choice for high compression ratios, such as air-cooled units and heat pumps, and has a range of **3 sizes and 31 models**.

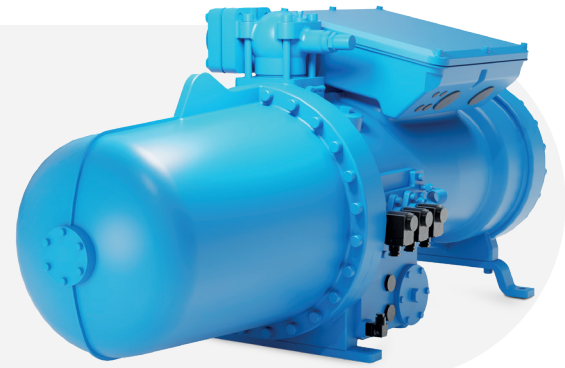

● Product information

4 FEATURES & BENEFITS



EFFICIENCY AND VERSATILITY



QUIET OPERATION



LONG-LASTING RELIABILITY



SAFE AND EASY OPERATION

CONFORMITY DECLARATION

Frascold Screw compressors are intended for installation in refrigeration systems.

The machine or partly completed machines shall comply with local safety regulation and standards of the place of installation **(within the EU according to the EU Directives 2006/42/EC Machinery Directive, 2014/68/EU Pressure Equipment Directive, 2006/95/EC Low Voltage Directive).**

The compressor may be put into operation only if it has been installed in accordance with the assembly instructions provided in the installation manual.

Commissioning is only possible if the entire system into which it is integrated has been inspected and approved in accordance to the provisions of legal regulations.

The standards applied are described in the Manufacturer Declaration of incorporation, according to the 2006/42/EC, and available at: **www.frascold.it**

PERFORMANCE DATA - FSS3 SOFTWARE

Please refer to our FSS3 Frascold Selection Software to check the performance of all our compressors.



OPERATING LIMITS



TECHNICAL INFORMATION



COOLING CAPACITY



DRAWINGS



ALL OPERATING DATA WITH ANY KIND OF REFRIGERANT



MANUALS



EUROPEAN STANDARD EN12900 AT 50Hz



CATALOGUES AND CERTIFICATIONS

ATEX CERTIFICATION



Our ATEX range of piston and screw compressors is certified in category 3G, with protective devices and systems providing a high level of protection in Zone 2: this refers to areas where an explosive atmosphere may be present, but only in rare cases and for short periods.

CE  II 3G IIB T3 Gc -20°C < Ta < 60°C

II: Group 2: Surface industries

3: Category 3 (Zone 2)

G: Use in an explosive atmosphere

IIB: Use with gas group IIB

Ta: Ambient temperature range

Gc: Equipment Protection Level

T3: T3 Category temperature (200°C)

UL CERTIFICATION



Frascold compressors with piston and screw technology are UL certified for the US and CSA certified for Canada. Certification is done according to safety standards UL60335-2, UL60335-1, CAN/CSA-C22.2 and UL684.

Our laboratory, which is accredited and certified by UL, performs the required tests and forwards the reports to UL experts.

The purpose of UL and CSA certifications is to ensure the highest safety standards both as mechanical strength of the body and electrical safety for the installer. In the rare case of electrical failure, the installer is assured of no electrical hazards or risks due to high temperature.

Compressor bodies are rechecked annually to confirm the veracity of the tests performed at the time of certification and the maintenance of quality.



CAPACITY



LEGAL DISCLAIMER: While Frascold has made every effort at the time of publication to ensure the accuracy of the information provided herein, product specifications and performances could be subject to change without notice. You can find the most updated information in our Frascold Selection Software FSS3 at the link: <https://www.frascold.it/en/software>

CX ARIA

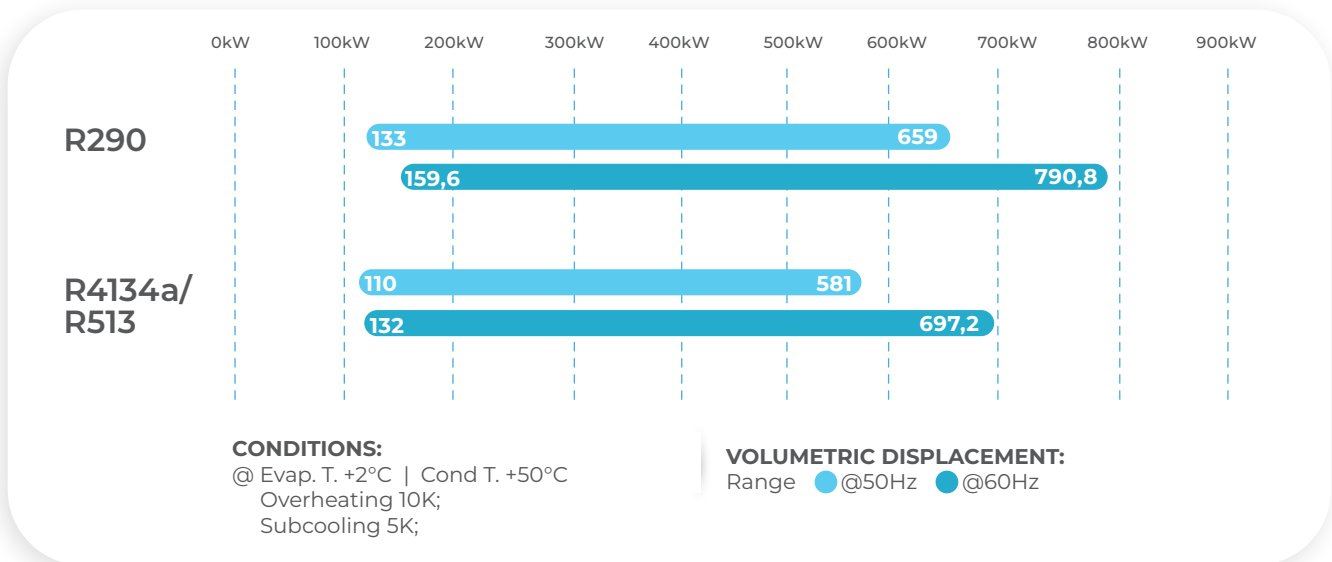

CX ACQUA

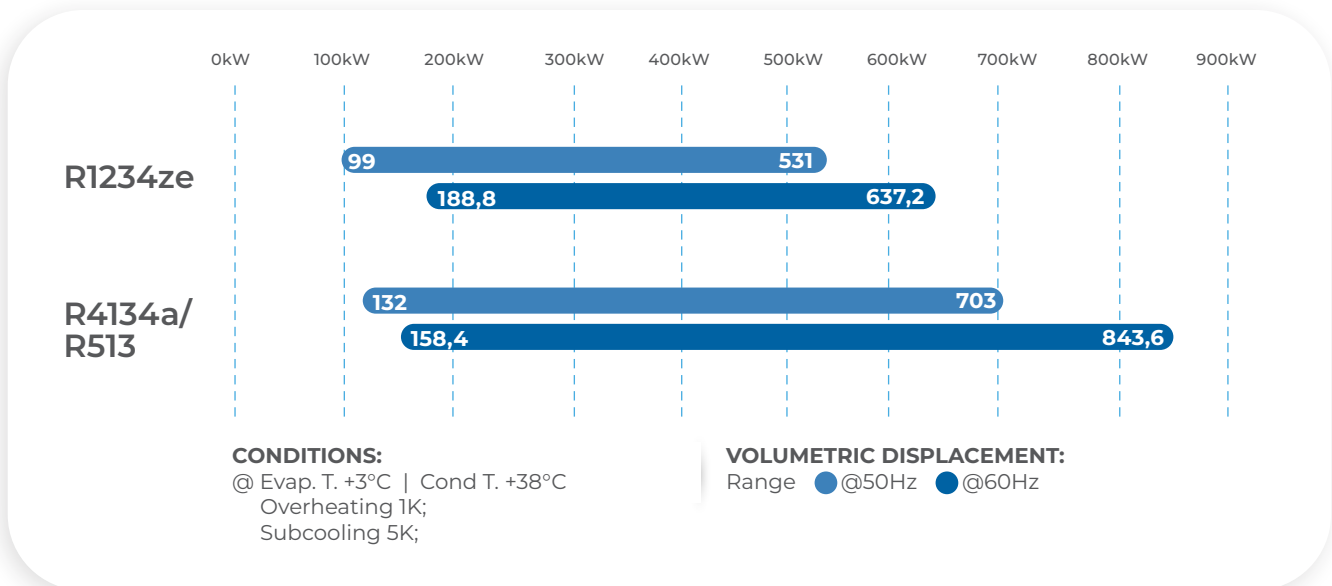

To visualize performance with other refrigerants, contact us or refer to the Frascold Selection Software FSS3: <https://www.frascold.it/software>

PRODUCT RANGE



CX ARIA

**SIZE
0**

Size 0: 11 models

50 - 120 HP
from 199 to 370 @50Hz
from 239 to 444 @60Hz

**SIZE
5**

Size 5: 8 models

110 - 160 HP
from 199 to 538 @50Hz
from 379 to 646 @60Hz

**SIZE
9**

Size 9: 12 models

160 - 310 HP
from 538 to 1085 @50Hz
from 646 to 1305 @60Hz

PRODUCT RANGE



CX ACQUA

**SIZE
0**

Size 0: 11 models

50 - 100 HP
from 199 to 370 @50Hz
from 239 to 444 @60Hz

**SIZE
5**

Size 5: 8 models

100 - 140 HP
from 199 to 538 @50Hz
from 514 to 646 @60Hz

**SIZE
9**

Size 9: 12 models

140 - 310 HP
from 620 to 1085 @50Hz
from 744 to 1032 @60Hz

MODEL DESIGNATION

CX H | 9 1 - 280 - 1000 Y

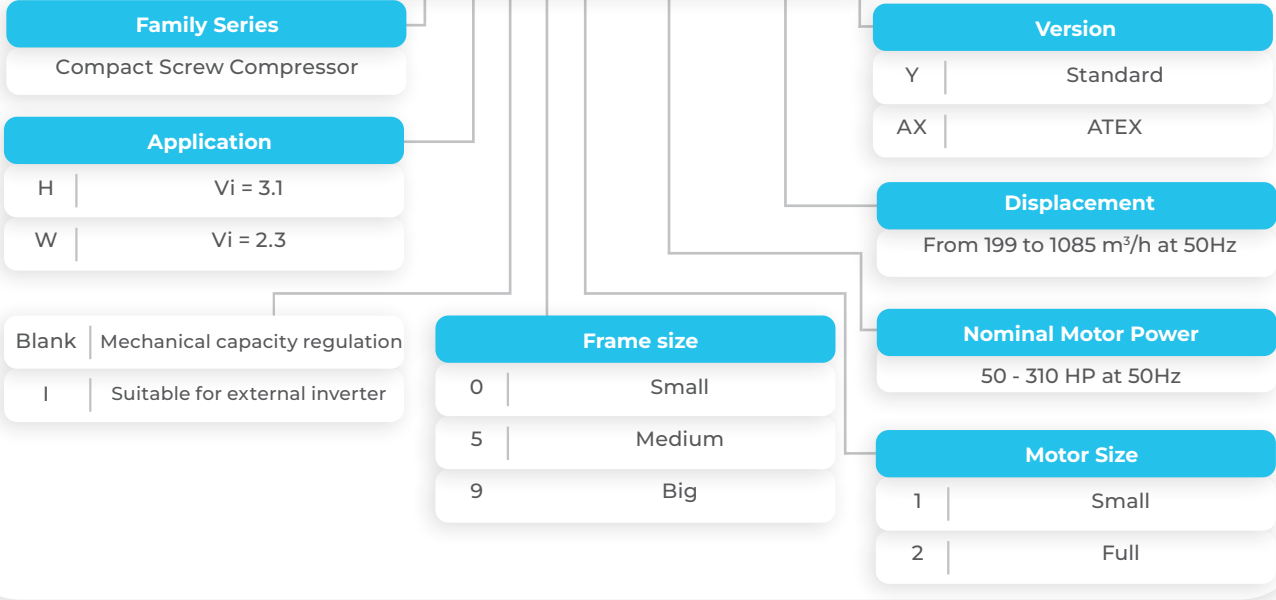

INFORMATION PLATE

All the important information to identify the compressor is displayed on the nameplate. The date of production is contained in the serial number. The user is responsible for indicating the refrigerant type.

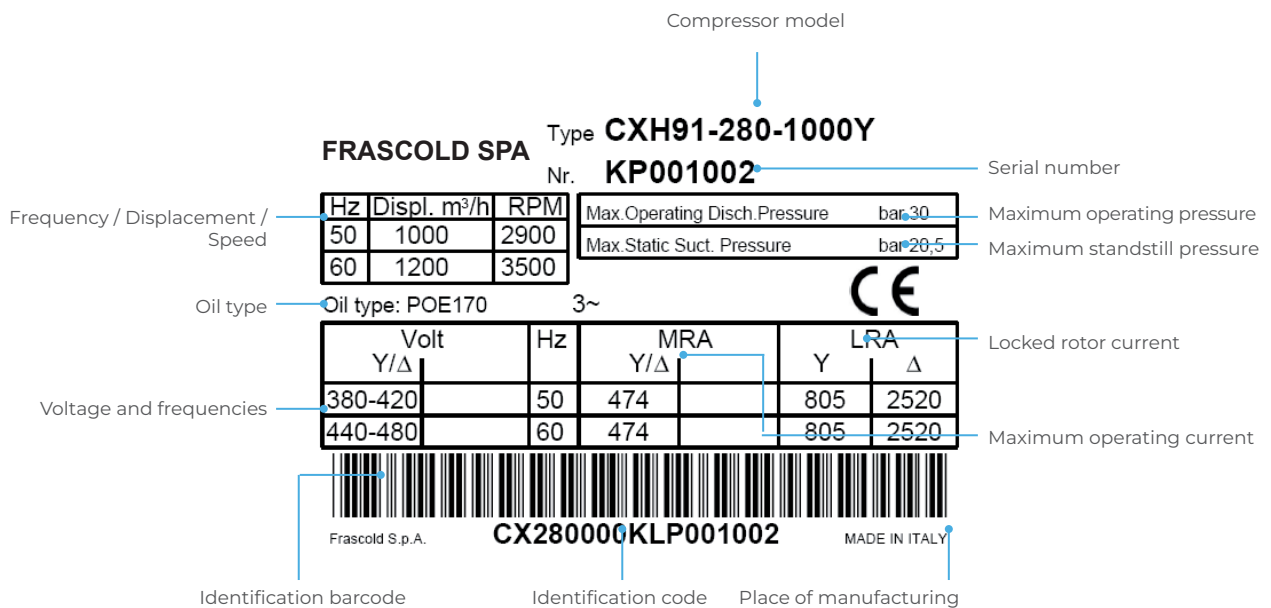

STANDARD EQUIPMENT AND OPTIONAL ACCESSORIES



Description	CX Aria	CX Acqua
Electronic Control Protection Module INT69FRY with manual reset. Standard power supply: AC 50-60 Hz 110-230V ± 10% 3 VA	■	■
INT69FRYL Diagnose - AC 50-60 Hz 24-230V ± 10% 3 VA	■	■
Integrated three stage internal oil separator	■	■
Crankcase heater	■	■
Replaceable oil filter	■	■
Two oil level (min & max) sight glasses (for 5 and 9 sizes)	■	■
POE 170 cSt lubricant charge (not included for CXH-W...AX version)	■	■
Discharge valve with soldering connections	■	■
Suction flange with solder sleeve	■	■
Axial suction layout for CXH-W91/2...1000/1085Y	■	■
Integrated check valve and safety valve	■	■
Step capacity control + unloaded start: 230V/1/50-60 coils (I version excluded)	■	■
Stepless capacity control	■	■
Nitrogen protective charge	■	■
Discharge Temperature PTC Sensor controlled by module INT69FRY	■	■
Packing ensuring proper handling and adequate protection	■	■
IP65 terminal box (IP66 for AX version)	■	■
Oil Drain Valve	■	■
Special voltage for electric motor	■	■
Suction Valve with soldering connections	■	■
Coils with different voltages	■	■
Axial suction layout (CXH-W91/2...1000/1085Y excluded)	■	■
Electronic oil level control	■	■
Oil Flow Switch (Standard for AX version)	■	■
Oil Filter Clogging Differential Pressure Switch (Electronic)	■	■
Electronic Alarm Control Module	■	■
Connection Kit for Economiser or Liquid Injection	■	■
Adapter Kit for External Oil cooler	■	■
Bridges for DOL Start (STD for I Version)	■	■
Rubber vibration dampers (4 pcs)	■	■
Special painting	■	■

■ Standard
 ■ Optional

CONTROL PROTECTION DEVICE

Standard compressor protection

The discharge temperature in certain conditions such as high condensing temperatures, low evaporating pressures or extremely high compression ratios, may reach values that can damage the compressor. All the models are supplied with the **INT69 FRY** electronic protection module, that stops the compressor in the event that the discharge temperature exceeds the set safety limit.

Optional compressor protection

Optionally, all compressors can be equipped with the new Kriwan **INT69 FRYL® Diagnose** protection module. This provides data logging, diagnostic, and protection features that can improve the reliability and service life of the compressor. Logged data can be used to aid in system optimization, identify problems and prevent malfunctions before they happen. The **INT69 FRYL® Diagnose** protection device has a dedicated connection port for the following compressor protection devices:

- Thermistor PTC (1, 2)
- Discharge temperature sensor (3, 4)
- Oil level check (5, 6)
- Oil filter clogging sensor (7, 8)
- Oil flowswitch (9, 10)



Protection features:

Data logged on the **INT69 FRYL® Diagnose** device can be downloaded via USB or DP-Modbus. This data can be used by technicians to correct system issues or conduct preemptive maintenance. The Kriwan mobile app for reading data may be downloaded directly and free of charge from the Google Play Store or from the App Store. In the event of a compressor malfunction, the device makes available the following features and data:

Safety Features

- Phase control
- Monitoring the number of start-ups
- Oil temperature check (and of discharge)
- Motor temperature check
- Oil level check
- Oil filter clogging check
- Oil flow check

Statistical Data

- Detailed list of the last 20 errors
- Number of on/off cycles
- Number of compressor start-ups
- Run times of compressor and accessories
- Number of start-ups over the last 7 days
- Maximum number of re-starts in an hour

CAPACITY REGULATION

The capacity of CX Frascold screw compressors can be adjusted with:

1 CAPACITY CONTROL (CC)*

2 VARIABLE FREQUENCY DRIVE (VFD)

1 CAPACITY CONTROL (CC)*

* on request

Step capacity control

CX compressors are supplied with a partialisation system with step capacity control, or stepless on request (see below). This system allows 4 steps of capacity reduction, corresponding to 25% (only for start up), 50%, 75%, 100% or the project cooling capacity. The capacity control is made through combinations of three solenoid valves.

Stepless capacity control

CX compressors can be turned into a stepless capacity control regulation (50-100%), by simply using a specific kit, containing a plate and a gasket (code T00WK1603 for compressors size 0 or T00WK1602 for compressors size 5 and 9).

The stepless capacity control is made by using three solenoid valves (V1, V2 and V3).

Step capacity control

	V3	V2	V1
25%	○	○	○
50%	○	●	●
75%	●	○	●
100%	○	○	●

Continuous capacity control

	V3	V2	V1
Start/stop	●	○	○
Increase at 50%	○	●	●
Increase (>50% -->100%)	○	○	⊙
Constant	○	○	○
Decrease (<100% -->50%)	○	⊙	○
Decrease before stop	●	○	○

- Solenoid valve energized
- Solenoid valve de-energized
- ⊙ Solenoid valve intermittent*
- ⊕ Solenoid valve pulsing*

*The time should be set to approximately 5 seconds on/5 seconds off.
** Pulse time is approximately 1-2 seconds

However, the right timing depends on the system operating conditions, and usage of adjustable time relays is recommended.

2 VARIABLE FREQUENCY DRIVE (VFD)

All the compressors are designed to be compatible with inverter technology and are suitable for operating within the frequency range (30=70 Hz). In some conditions of use, a restriction on the range of frequency might apply.

In particular, the maximum frequency depends on the maximum operational current (MRA). For performance data at the various frequencies and the maximum limits under each condition, see Frascold selection software.

Calculate maximum frequency

Within the limits of use of each specific compressor and refrigerant for each work point, there is a maximum frequency not to be exceeded, which can be calculated using the following formula:

$$f(\text{Max}) = \frac{\text{MRA} \times 50 \text{ Hz}}{I_e}$$

f(Max) = maximum possible frequency [Hz]
MRA = maximum operational current [A]
Ie = current absorbed at the work point at 50 Hz [A]

Calculate corresponding capacity

The refrigeration capacity is calculated as a function of the frequency using the following formula:

$$Q_0(f) = \frac{f_a \times Q_0 50 \text{ Hz}}{50 \text{ Hz}}$$

Q0 (f) = refrigeration capacity at working frequency [W]
fa = actual frequency applied to the compressor [Hz]
Q0 50 Hz = refrigeration capacity at 50 Hz [W]

CX ARIA

Motor Power supply 400V / 3 / 50Hz | 460V / 3 / 60Hz | PWS Connection

Models	Motor Vers.	Displacement		Nominal power at 50Hz	Capacity control	Valid for VFD regulation		MRA	LRA. PWS Motor	LRA. DOL Motor
		50Hz	60Hz			Frequency min.	Frequency max.			
		[m ³ /h]	[HP]	[%]	[Hz]	[A]				
CXH01-50-199Y	1	199	238.8	50	75% - 50% - 25%	30	70	80	203	330
CXH01-60-230Y	1	230	276	60	75% - 50% - 25%	30	70	98	262	425
CXH01-70-264Y	1	264	316.8	70	75% - 50% - 25%	30	70	125	298	518
CXH01-80-298Y	1	298	357.6	80	75% - 50% - 25%	30	70	145	373	600
CXH01-90-340Y	1	340	408	90	75% - 50% - 25%	30	70	152	405	649
CXH01-100-370Y	1	370	444	100	75% - 50% - 25%	30	70	169	488	767
CXH51-110-398Y	1	398	477.6	110	75% - 50% - 25%	30	70	180	434	720
CXH51-125-468Y	1	468	561.6	125	75% - 50% - 25%	30	70	198	530	838
CXH51-140-538Y	1	538	645.6	140	75% - 50% - 25%	30	70	221	587	921
CXH91-160-620Y	1	620	744	160	75% - 50% - 25%	30	70	283	436	1364
CXH91-180-702Y	1	702	842.4	180	75% - 50% - 25%	30	70	315	465	1442
CXH91-210-810Y	1	810	972	210	75% - 50% - 25%	30	70	356	586	1853
CXH91-240-912Y	1	912	1094.4	240	75% - 50% - 25%	30	60	427	650	2029
CXH91-280-1000Y	1	1000	1200	280	75% - 50% - 25%	30	60	474	805	2520
CXH91-310-1085Y	1	1085	1302	310	75% - 50% - 25%	30	60	490	805	2520
CXH02-70-199Y	2	199	238.8	70	75% - 50% - 25%	30	70	128	298	518
CXH02-80-230Y	2	230	276	80	75% - 50% - 25%	30	70	145	373	600
CXH02-90-264Y	2	264	316.8	90	75% - 50% - 25%	30	70	160	405	649
CXH02-100-298Y	2	298	357.6	100	75% - 50% - 25%	30	70	175	488	767
CXH02-120-340Y	2	340	408	120	75% - 50% - 25%	30	70	195	505	793
CXH52-110-316Y	2	316	379.2	110	75% - 50% - 25%	30	70	184	434	720
CXH52-125-372Y	2	372	446.4	125	75% - 50% - 25%	30	70	218	530	838
CXH52-140-428Y	2	428	513.6	140	75% - 50% - 25%	30	70	245	587	921
CXH52-160-468Y	2	468	561.6	160	75% - 50% - 25%	30	70	282	729	1114
CXH52-180-538Y	2	538	645.6	180	75% - 50% - 25%	30	70	304	786	1209
CXH92-180-545Y	2	545	654	180	75% - 50% - 25%	30	70	332	465	1442
CXH92-210-620Y	2	620	744	210	75% - 50% - 25%	30	70	375	586	1853
CXH92-240-702Y	2	702	842.4	240	75% - 50% - 25%	30	70	427	650	2029
CXH92-280-810Y	2	810	972	280	75% - 50% - 25%	30	60	455	805	2520
CXH92-300-912Y	2	912	1094.4	300	75% - 50% - 25%	30	60	474	805	2520
CXH92-310-1000Y	2	1000	1200	310	75% - 50% - 25%	30	60	474	805	2520

Data reference valid for the same model in version CXH and CXHI.

LEGAL DISCLAIMER:

While Frascold has made every effort at the time of publication to ensure the accuracy of the information provided herein, product specifications and performances could be subject to change without notice. You can find the most updated information in our Frascold Selection Software FSS3 at the link: <https://www.frascold.it/en/software>

CX ARIA Motor Power supply 400V / 3 / 50Hz | 460V / 3 / 60Hz | PWS Connection

Models	Protection Index	Maximum standstill pressure	Maximum operative pressure	Suction valve	Suction Valve	Discharge Valve	Discharge Valve	Suction line	Suction line	Net Weight
	[IP]			(SV)		(DV)		(SL)		
		[bar]	[mm]	[inch]	[mm]	[inch]	[mm]	[inch]	[kg]	
CXH01-50-199Y	IP56	20,5	30	80	3 1/8"	54	2 1/8"	80	3 1/8"	532
CXH01-60-230Y	IP56	20,5	30	80	3 1/8"	54	2 1/8"	80	3 1/8"	540
CXH01-70-264Y	IP56	20,5	30	80	3 1/8"	54	2 1/8"	80	3 1/8"	547
CXH01-80-298Y	IP56	20,5	30	80	3 1/8"	54	2 1/8"	80	3 1/8"	549
CXH01-90-340Y	IP56	20,5	30	80	3 1/8"	54	2 1/8"	80	3 1/8"	551
CXH01-100-370Y	IP56	20,5	30	80	3 1/8"	54	2 1/8"	80	3 1/8"	553
CXH51-110-398Y	IP56	20,5	30	105	4 1/8"	80	DN80	105	4 1/8"	781
CXH51-125-468Y	IP56	20,5	30	105	4 1/8"	80	DN80	105	4 1/8"	803
CXH51-140-538Y	IP56	20,5	30	105	4 1/8"	80	DN80	105	4 1/8"	802
CXH91-160-620Y	IP56	20,5	30	105	4 1/8"	80	DN80	105	4 1/8"	1348
CXH91-180-702Y	IP56	20,5	30	105	4 1/8"	80	DN80	105	4 1/8"	1355
CXH91-210-810Y	IP56	20,5	30	125	DN125	105	4 1/8"	DN125	DN125	1405
CXH91-240-912Y	IP56	20,5	30	125	DN125	105	4 1/8"	DN125	DN125	1410
CXH91-280-1000Y	IP56	20,5	30	125	DN125	105	4 1/8"	DN125	DN125	1470
CXH91-310-1085Y	IP56	20,5	30	125	DN125	105	4 1/8"	DN125	DN125	1490
CXH02-70-199Y	IP56	20,5	30	80	3 1/8"	54	2 1/8"	80	3 1/8"	545
CXH02-80-230Y	IP56	20,5	30	80	3 1/8"	54	2 1/8"	80	3 1/8"	550
CXH02-90-264Y	IP56	20,5	30	80	3 1/8"	54	2 1/8"	80	3 1/8"	552
CXH02-100-298Y	IP56	20,5	30	80	3 1/8"	54	2 1/8"	80	3 1/8"	560
CXH02-120-340Y	IP56	20,5	30	80	3 1/8"	54	2 1/8"	105	3 1/8"	563
CXH52-110-316Y	IP56	20,5	30	105	4 1/8"	80	DN80	80	4 1/8"	798
CXH52-125-372Y	IP56	20,5	30	105	4 1/8"	80	DN80	105	4 1/8"	800
CXH52-140-428Y	IP56	20,5	30	105	4 1/8"	80	DN80	105	4 1/8"	803
CXH52-160-468Y	IP56	20,5	30	105	4 1/8"	80	DN80	105	4 1/8"	805
CXH52-180-538Y	IP56	20,5	30	105	4 1/8"	80	DN80	105	4 1/8"	807
CXH92-180-545Y	IP56	20,5	30	105	4 1/8"	80	DN80	105	4 1/8"	1380
CXH92-210-620Y	IP56	20,5	30	105	4 1/8"	80	DN80	105	4 1/8"	1392
CXH92-240-702Y	IP56	20,5	30	105	4 1/8"	80	DN80	105	4 1/8"	1385
CXH92-280-810Y	IP56	20,5	30	125	DN125	105	4 1/8"	DN125	DN125	1410
CXH92-300-912Y	IP56	20,5	30	125	DN125	105	4 1/8"	DN125	DN125	1415
CXH92-310-1000Y	IP56	20,5	30	125	DN125	105	4 1/8"	DN125	DN125	1480

Find the most updated information and other supply voltages in our Frascold Selection Software FSS3 at the link: <https://www.frascold.it/en/software>

CX ACQUA **Motor Power supply** 400V / 3 / 50Hz | 460V / 3 / 60Hz | PWS Connection

Models	Motor Vers.	Displacement		Nominal power at 50Hz	Capacity control	Valid for VFD regulation		MRA	LRA. PWS Motor	LRA. DOL Motor
		50Hz	60Hz			Frequency min.	Frequency max.			
		[m ³ /h]	[HP]	[%]	[Hz]	[A]				
CXW01-50-230Y	1	230	276	50	75% - 50% - 25%	30	70	80	203	330
CXW01-60-264Y	1	264	316,8	60	75% - 50% - 25%	30	70	98	262	425
CXW01-70-298Y	1	298	357,6	70	75% - 50% - 25%	30	70	125	298	518
CXW01-80-340Y	1	340	408	80	75% - 50% - 25%	30	70	134	373	600
CXW01-90-370Y	1	370	444	90	75% - 50% - 25%	30	70	160	405	649
CXW51-100-428Y	1	428	513,6	100	75% - 50% - 25%	30	70	180	434	720
CXW51-110-468Y	1	468	561,6	110	75% - 50% - 25%	30	70	187	434	720
CXW51-125-538Y	1	538	645,6	125	75% - 50% - 25%	30	70	198	530	838
CXW91-140-620Y	1	620	744	140	75% - 50% - 25%	30	70	255	436	1364
CXW91-160-702Y	1	702	842,4	160	75% - 50% - 25%	30	70	283	436	1364
CXW91-180-810Y	1	810	972	180	75% - 50% - 25%	30	70	315	465	1442
CXW91-210-912Y	1	912	1094,4	210	75% - 50% - 25%	30	60	356	586	1853
CXW91-240-1000Y	1	1000	1200	240	75% - 50% - 25%	30	60	427	650	2029
CXW91-280-1085Y	1	1085	1302	280	75% - 50% - 25%	30	60	455	805	2520
CXW02-50-199Y	2	199	238,8	50	75% - 50% - 25%	30	70	85	203	330
CXW02-60-230Y	2	230	276	60	75% - 50% - 25%	30	70	101	262	425
CXW02-70-264Y	2	264	316,8	70	75% - 50% - 25%	30	70	125	298	518
CXW02-80-298Y	2	298	357,6	80	75% - 50% - 25%	30	70	145	373	600
CXW02-90-340Y	2	340	408	90	75% - 50% - 25%	30	70	160	405	649
CXW02-100-370Y	2	370	444	100	75% - 50% - 25%	30	70	175	488	767
CXW52-110-428Y	2	428	513,6	110	75% - 50% - 25%	30	70	184	434	720
CXW52-125-468Y	2	468	516,6	125	75% - 50% - 25%	30	70	219	530	838
CXW52-140-538Y	2	538	645,6	140	75% - 50% - 25%	30	70	235	587	921
CXW92-160-620Y	2	620	744	160	75% - 50% - 25%	30	70	283	436	1364
CXW92-180-702Y	2	702	824,4	180	75% - 50% - 25%	30	70	315	465	1442
CXW92-210-810Y	2	810	972	210	75% - 50% - 25%	30	70	356	586	1853
CXW92-240-912Y	2	912	1094,4	240	75% - 50% - 25%	30	60	427	650	2029
CXW92-280-1000Y	2	1000	1200	280	75% - 50% - 25%	30	60	455	805	2520
CXW92-310-1085Y	2	1085	1302	310	75% - 50% - 25%	30	60	490	805	2520

LEGAL DISCLAIMER:

While Frascold has made every effort at the time of publication to ensure the accuracy of the information provided herein, product specifications and performances could be subject to change without notice. You can find the most updated information in our Frascold Selection Software FSS3 at the link: <https://www.frascold.it/en/software>

CX ACQUA **Motor Power supply** 400V / 3 / 50Hz | 460V / 3 / 60Hz | PWS Connection

Models	Protection Index	Maximum standstill pressure	Maximum operative pressure	Suction valve	Suction Valve	Discharge Valve	Discharge Valve	Suction line	Suction line	Net Weight
	[IP]			(SV)		(DV)		(SL)		
				[bar]	[mm]	[inch]	[mm]	[inch]	[mm]	
CXW01-50-230Y	IP56	20,5	30	80	3 1/8"	54	2 1/8"	80	3 1/8"	490
CXW01-60-264Y	IP56	20,5	30	80	3 1/8"	54	2 1/8"	80	3 1/8"	500
CXW01-70-298Y	IP56	20,5	30	80	3 1/8"	54	2 1/8"	80	3 1/8"	505
CXW01-80-340Y	IP56	20,5	30	80	3 1/8"	54	2 1/8"	80	3 1/8"	510
CXW01-90-370Y	IP56	20,5	30	80	3 1/8"	54	2 1/8"	80	3 1/8"	525
CXW51-100-428Y	IP56	20,5	30	105	4 1/8"	80	DN80	105	4 1/8"	840
CXW51-110-468Y	IP56	20,5	30	105	4 1/8"	80	DN80	105	4 1/8"	850
CXW51-125-538Y	IP56	20,5	30	105	4 1/8"	80	DN80	105	4 1/8"	865
CXW91-140-620Y	IP56	20,5	30	105	4 1/8"	80	DN80	105	4 1/8"	1475
CXW91-160-702Y	IP56	20,5	30	105	4 1/8"	80	DN80	105	4 1/8"	1465
CXW91-180-810Y	IP56	20,5	30	125	DN125	105	4 1/8"	DN125	DN125	1465
CXW91-210-912Y	IP56	20,5	30	125	DN125	105	4 1/8"	DN125	DN125	1465
CXW91-240-1000Y	IP56	20,5	30	125	DN125	105	4 1/8"	DN125	DN125	1490
CXW91-280-1085Y	IP56	20,5	30	125	DN125	105	4 1/8"	DN125	DN125	1490
CXW02-50-199Y	IP56	20,5	30	80	3 1/8"	54	2 1/8"	80	3 1/8"	490
CXW02-60-230Y	IP56	20,5	30	80	3 1/8"	54	2 1/8"	80	3 1/8"	505
CXW02-70-264Y	IP56	20,5	30	80	3 1/8"	54	2 1/8"	80	3 1/8"	500
CXW02-80-298Y	IP56	20,5	30	80	3 1/8"	54	2 1/8"	80	3 1/8"	515
CXW02-90-340Y	IP56	20,5	30	80	3 1/8"	54	2 1/8"	80	3 1/8"	525
CXW02-100-370Y	IP56	20,5	30	80	3 1/8"	54	2 1/8"	80	3 1/8"	540
CXW52-110-428Y	IP56	20,5	30	105	4 1/8"	80	DN80	80	3 1/8"	840
CXW52-125-468Y	IP56	20,5	30	105	4 1/8"	80	DN80	105	4 1/8"	875
CXW52-140-538Y	IP56	20,5	30	105	4 1/8"	80	DN80	105	4 1/8"	878
CXW92-160-620Y	IP56	20,5	30	105	4 1/8"	80	DN80	105	4 1/8"	1475
CXW92-180-702Y	IP56	20,5	30	105	4 1/8"	80	DN80	105	4 1/8"	1475
CXW92-210-810Y	IP56	20,5	30	125	DN125	105	4 1/8"	DN125	DN125	1475
CXW92-240-912Y	IP56	20,5	30	125	DN125	105	4 1/8"	DN125	DN125	1475
CXW92-280-1000Y	IP56	20,5	30	125	DN125	105	4 1/8"	DN125	DN125	1490
CXW92-310-1085Y	IP56	20,5	30	125	DN125	105	4 1/8"	DN125	DN125	1490

Find the most updated information and other supply voltages in our Frascold Selection Software FSS3 at the link: <https://www.frascold.it/en/software>

OPERATING LIMITS

For specific model and refrigerant performance data, please use the FSS3 Frascold Selection Software available for free download at <https://www.frascold.it/software>

Motor 1 - Full load operation (100%)

Motor 2 - Full load operation (100%)

R134a - CXH

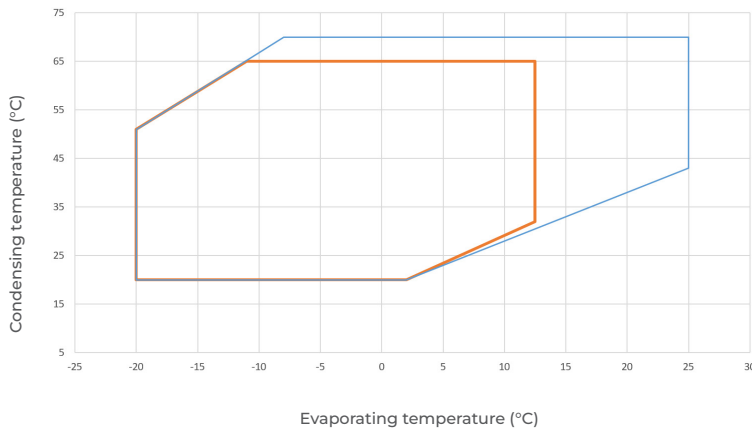

- Full load operation (100%) - motor 1
- Full load operation (100%) - motor 2

Suction gas superheating 10K

R134a - CXW

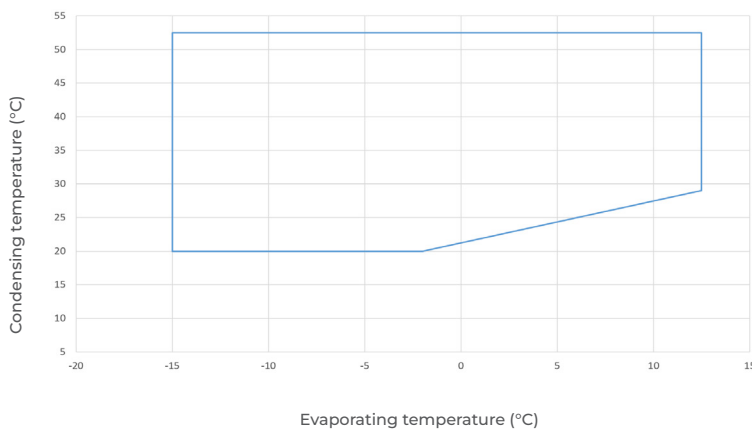

- Full load operation (100%) - motor 1

Suction gas superheating 10K

LEGAL DISCLAIMER:

While Frascold has made every effort at the time of publication to ensure the accuracy of the information provided herein, product specifications and performances could be subject to change without notice. You can find the most updated information in our Frascold Selection Software FSS3 at the link: <https://www.frascold.it/en/software>

OPERATING LIMITS



R290 - CXH / CXHI

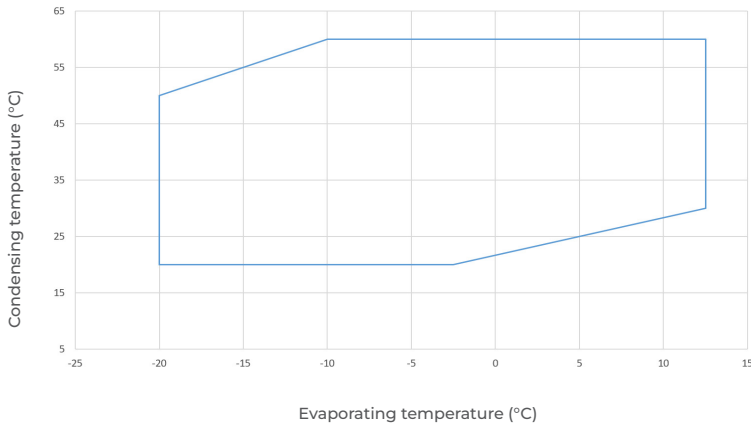

Full load operation (100%) - motor 1
50Hz
Suction gas superheating 10K

R600a - CXH

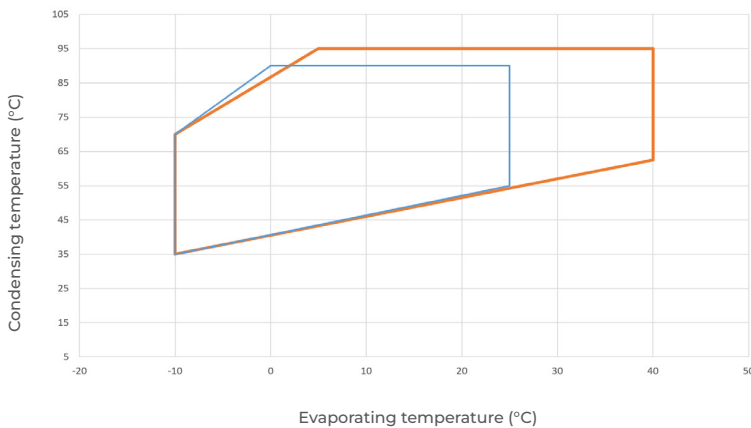

Full load operation (100%) - motor 1
 Full load operation (100%) - motor 2
Suction gas superheating 10K

R1234ze(E) - CXH

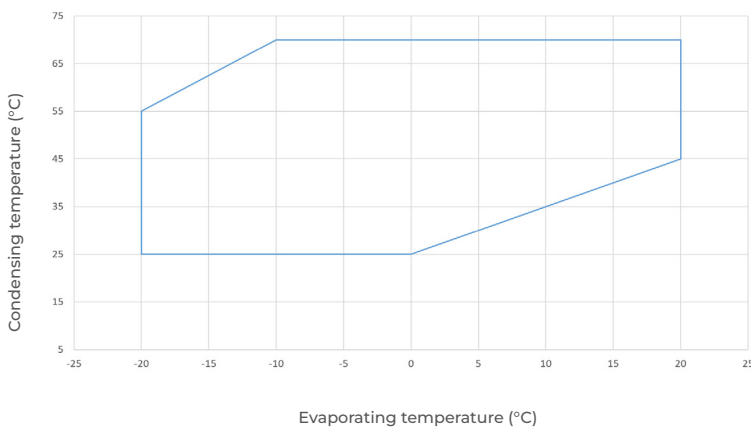

Full load operation (100%) - motor 1
50Hz
Suction gas superheating 10K

TECHNICAL DRAWINGS AND DIMENSIONS

CXH-0-CXW-0

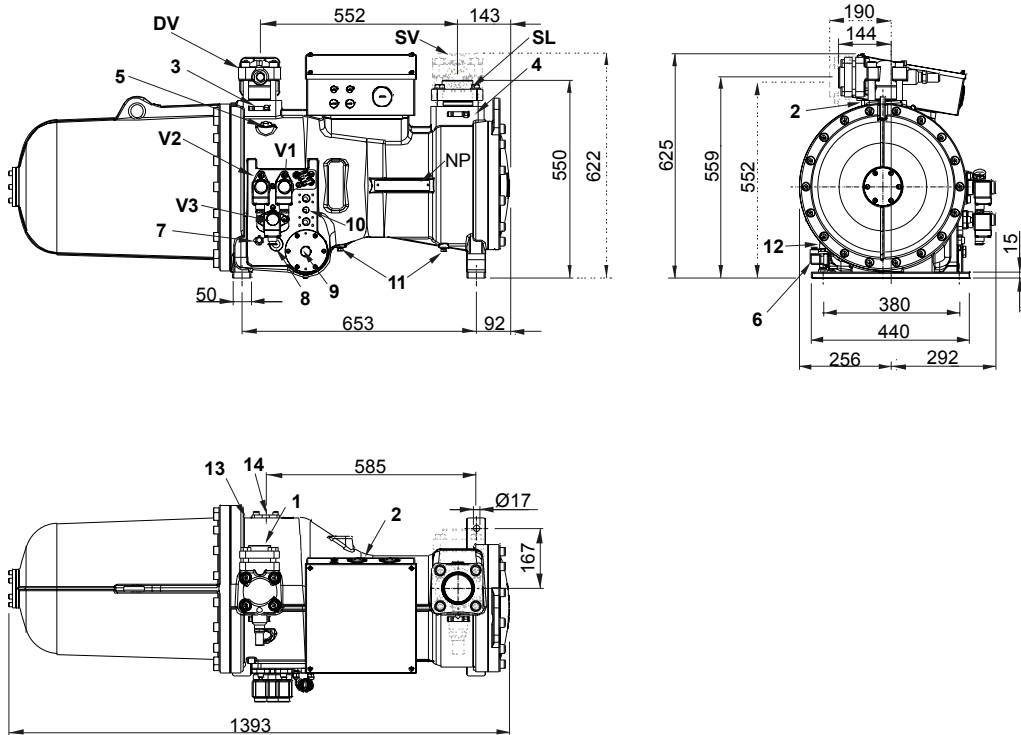

1	High pressure connection	1/8" NPT
2	Low pressure connection	1/8" NPT
3	High pressure connection	1/4" SAE x 1/4" SAE
4	Low pressure connection	1/4" SAE x 1/4" SAE
5	Oil charge plug	3/8" GAS
6	Crankcase heater	
7	Oil level regulator connection	3/4" NPT
8	Oil level sight glass	
9	Filter clogging sensor connection	1/2" GAS
10	Oil cooler connection	1/2" NPT
11	Oil drain plug	1/4" NPT
12	Oil drain valve	1/8" NPT
13	Maximum oil temperature sensor	
14	ECO/Liquid injection connection	1-1/8"
SV	Suction valve	3-1/8" - 80 mm
DV	Discharge valve	2-1/8" - 54 mm
SL	Suction line	3-1/8"
V1	Capacity control valve	
V2	Capacity control valve	
V3	Capacity control valve	

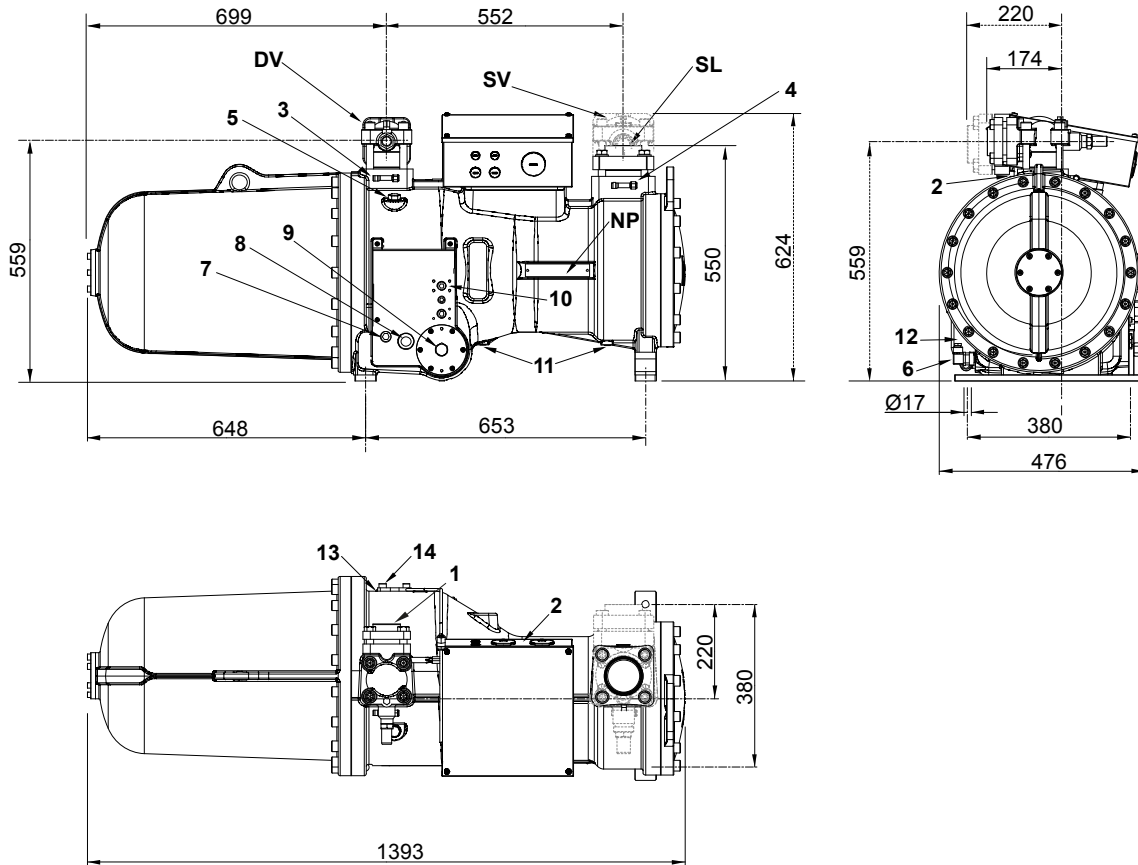

1	High pressure connection	1/8" NPT
2	Low pressure connection	1/8" NPT
3	High pressure connection	1/4" SAE x 1/4" SAE
4	Low pressure connection	1/4" SAE x 1/4" SAE
5	Oil charge plug	3/8" GAS
6	Crankcase heater	
7	Oil level regulator connection	3/4" NPT
8	Oil level sight glass	
9	Filter clogging sensor connection	1/2" GAS
10	Oil cooler connection	1/2" NPT
11	Oil drain plug	1/4" NPT
12	Oil drain valve	1/8" NPT
13	Maximum oil temperature sensor	
14	ECO/Liquid injection connection	1-1/8"
SV	Suction valve	3-1/8" - 80 mm
DV	Discharge valve	2-1/8" - 54 mm
SL	Suction line	3-1/8"
V1	Capacity control valve	
V2	Capacity control valve	
V3	Capacity control valve	

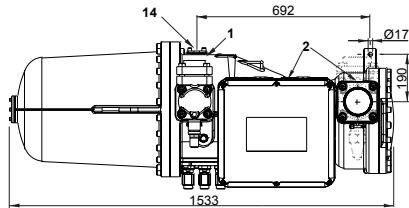
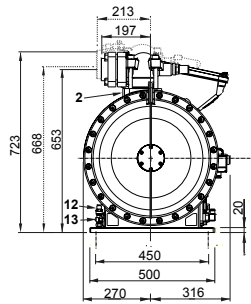
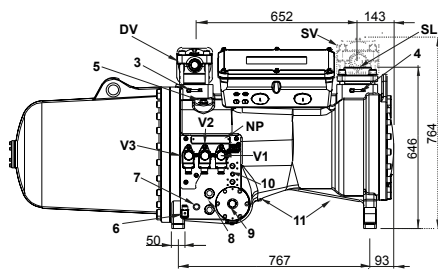

STANDARD

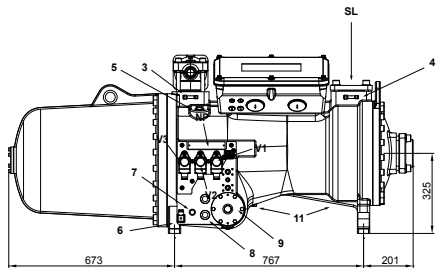

WITH AXIAL SUCTION

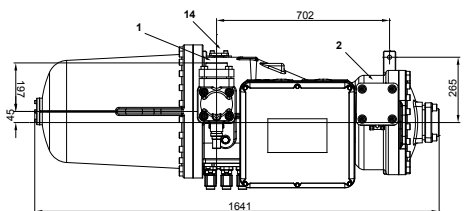
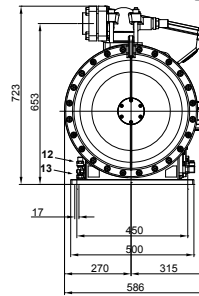

1	High pressure connection	1/8" NPT
2	Low pressure connection	1/8" NPT
3	High pressure connection	1/4" SAE x 1/4" SAE
4	Low pressure connection	1/4" SAE x 1/4" SAE
5	Oil charge plug	3/8" GAS
6	Crankcase heater	
7	Oil level regulator connection	3/4" NPT
8	Oil level sight glass	
9	Filter clogging sensor connection	1/2" GAS
10	Oil cooler connection	1/2" NPT
11	Oil drain plug	1/4" NPT
12	Oil drain valve	1/8" NPT
13	Maximum oil temperature sensor	
14	ECO/Liquid injection connection	1 1/8"
SV	Suction valve	4-1/8" - 105 mm
DV	Discharge valve	DN80
SL	Suction line	4-1/8"
V1	Capacity control valve	
V2	Capacity control valve	
V3	Capacity control valve	

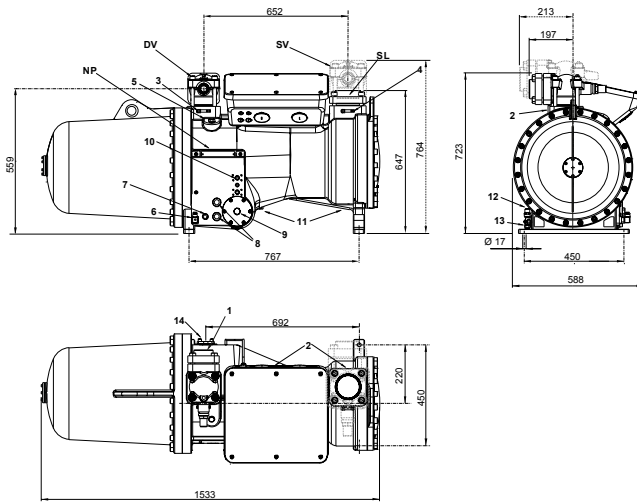

STANDARD

WITH AXIAL SUCTION

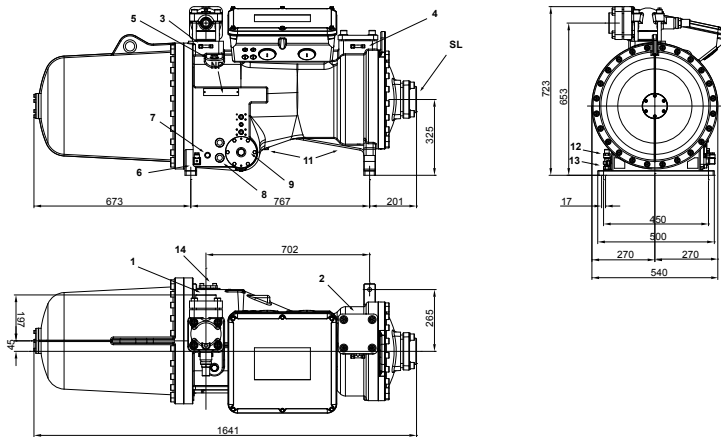

1	High pressure connection	1/8" NPT
2	Low pressure connection	1/8" NPT
3	High pressure connection	1/4" SAE x 1/4" SAE
4	Low pressure connection	1/4" SAE x 1/4" SAE
5	Oil charge plug	3/8" GAS
6	Crankcase heater	
7	Oil level regulator connection	3/4" NPT
8	Oil level sight glass	
9	Filter clogging sensor connection	1/2" GAS
10	Oil cooler connection	1/2" NPT
11	Oil drain plug	1/4" NPT
12	Oil drain valve	1/8" NPT
13	Maximum oil temperature sensor	
14	ECO/Liquid injection connection	1-1/8"
SV	Suction valve	4-1/8" - 105 mm
DV	Discharge valve	DN80
SL	Suction line	4-1/8"
V1	Capacity control valve	
V2	Capacity control valve	
V3	Capacity control valve	

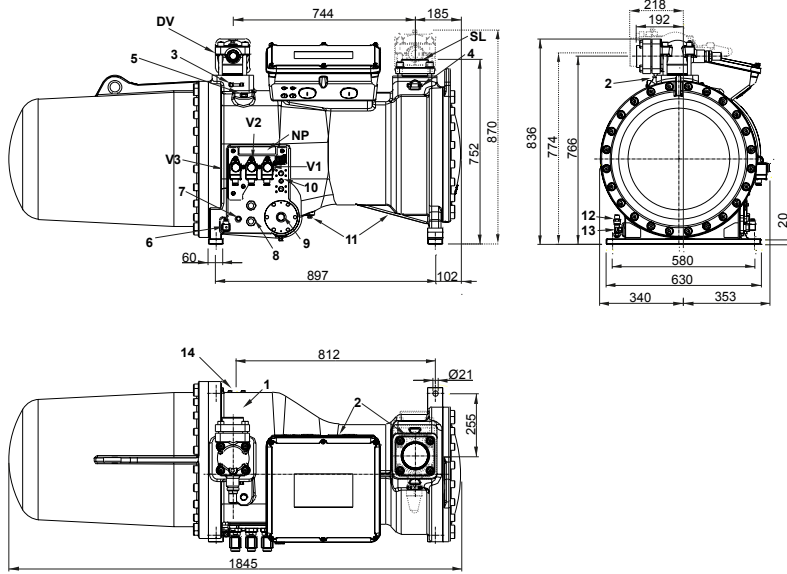

STANDARD

WITH AXIAL SUCTION

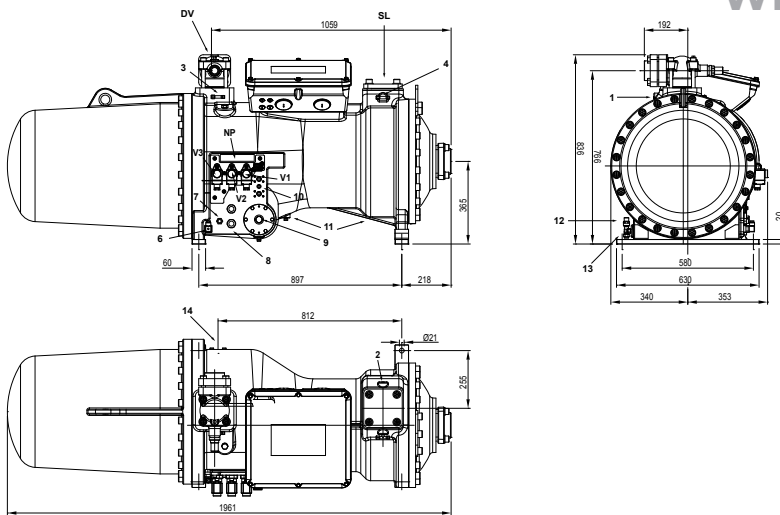

1	High pressure connection	1/8" NPT
2	Low pressure connection	1/8" NPT
3	High pressure connection	1/4" SAE x 1/4" SAE
4	Low pressure connection	1/4" SAE x 1/4" SAE
5	Oil charge plug	3/8" GAS
6	Crankcase heater	
7	Oil level regulator connection	3/4" NPT
8	Oil level sight glass	
9	Filter clogging sensor connection	1/2" GAS
10	Oil cooler connection	1/2" NPT
11	Oil drain plug	1/4" NPT
12	Oil drain valve	1/8" NPT
13	Maximum oil temperature sensor	
14	ECO/Liquid injection connection	1-1/8"
SV	Suction valve	4-1/8" - 105 mm
DV	Discharge valve	DN80
SL	Suction line	4-1/8"
V1	Capacity control valve	
V2	Capacity control valve	
V3	Capacity control valve	

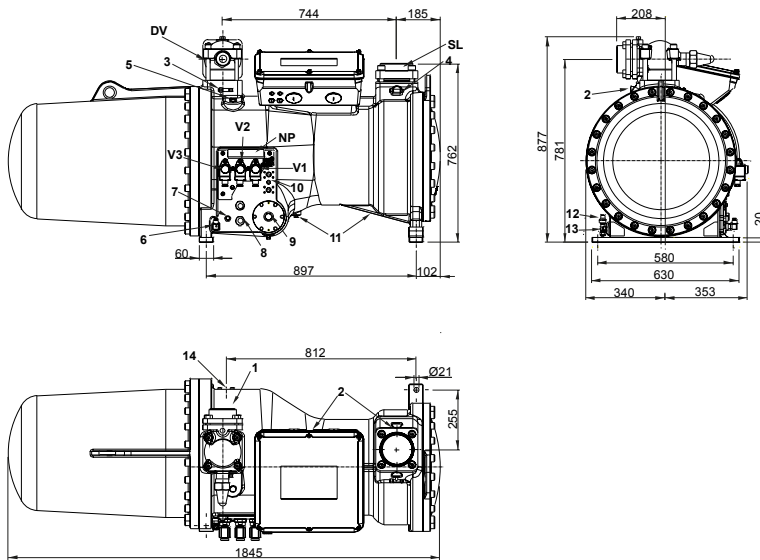

STANDARD

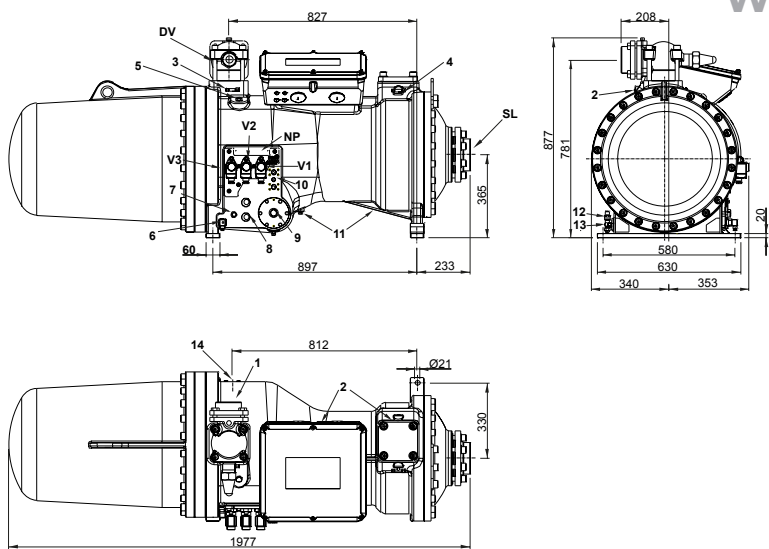

WITH AXIAL SUCTION

1	High pressure connection	1/8" NPT
2	Low pressure connection	1/8" NPT
3	High pressure connection	1/4" SAE x 1/4" SAE
4	Low pressure connection	1/4" SAE x 1/4" SAE
5	Oil charge plug	3/8" GAS
6	Crankcase heater	
7	Oil level regulator connection	3/4" NPT
8	Oil level sight glass	
9	Filter clogging sensor connection	1/2" GAS
10	Oil cooler connection	1/2" NPT
11	Oil drain plug	1/4" NPT
12	Oil drain valve	1/8" NPT
13	Maximum oil temperature sensor	
14	ECO/Liquid injection connection	1-1/8"
SV	Suction valve	DN125
DV	Discharge valve	4-1/8" - 105 mm
SL	Suction line	DN125
V1	Capacity control valve	
V2	Capacity control valve	
V3	Capacity control valve	

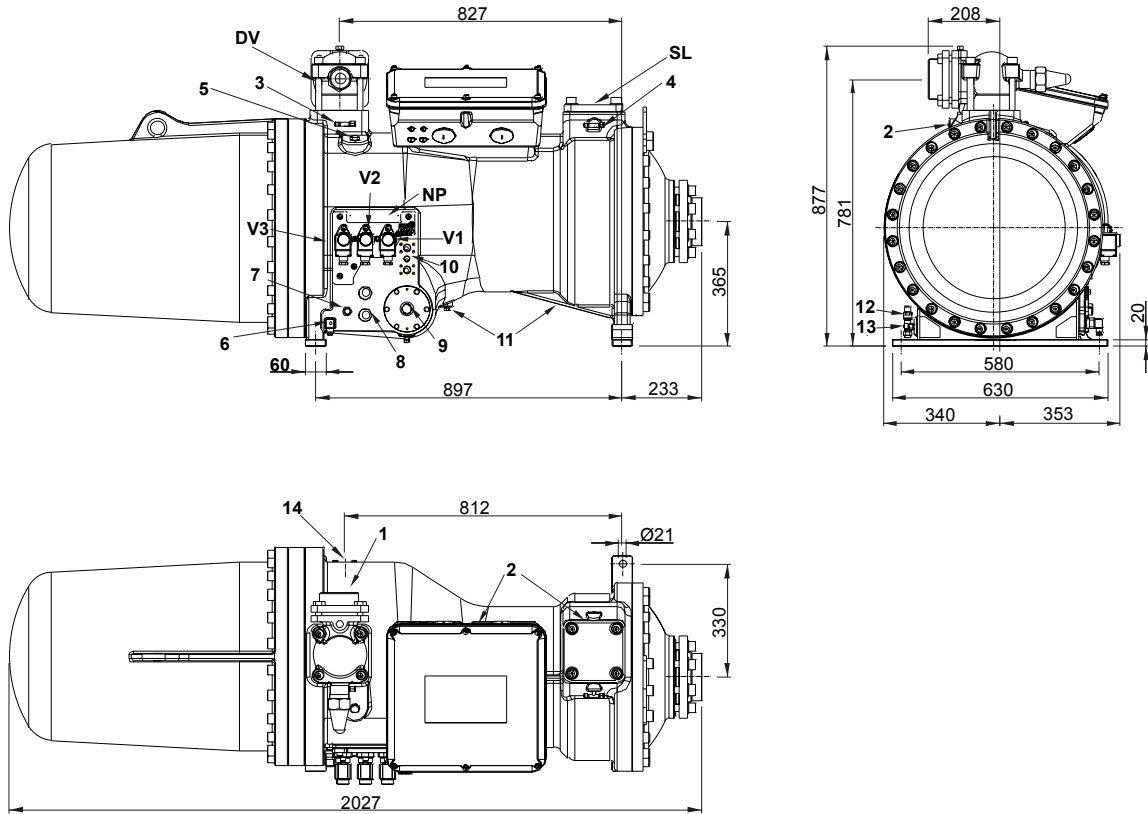

1	High pressure connection	1/8" NPT
2	Low pressure connection	1/8" NPT
3	High pressure connection	1/4" SAE x 1/4" SAE
4	Low pressure connection	1/4" SAE x 1/4" SAE
5	Oil charge plug	3/8" GAS
6	Crankcase heater	
7	Oil level regulator connection	3/4" NPT
8	Oil level sight glass	
9	Filter clogging sensor connection	1/2" GAS
10	Oil cooler connection	1/2" NPT
11	Oil drain plug	1/4" NPT
12	Oil drain valve	1/8" NPT
13	Maximum oil temperature sensor	
14	ECO/Liquid injection connection	1-1/8"
SV	Suction valve	DN125
DV	Discharge valve	4-1/8" - 105 mm
SL	Suction line	DN125
V1	Capacity control valve	
V2	Capacity control valve	
V3	Capacity control valve	

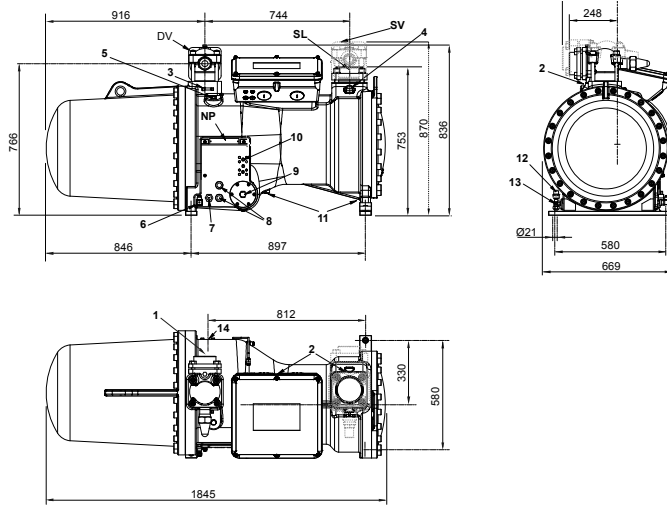

STANDARD

WITH AXIAL SUCTION

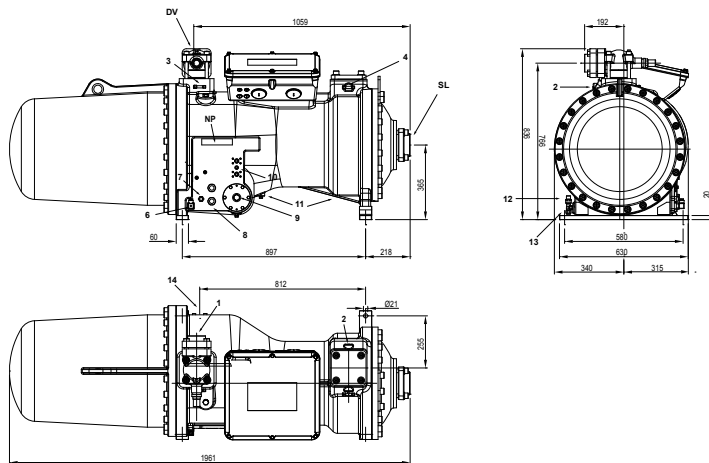

1	High pressure connection	1/8" NPT
2	Low pressure connection	1/8" NPT
3	High pressure connection	1/4" SAE x 1/4" SAE
4	Low pressure connection	1/4" SAE x 1/4" SAE
5	Oil charge plug	3/8" GAS
6	Crankcase heater	
7	Oil level regulator connection	3/4" NPT
8	Oil level sight glass	
9	Filter clogging sensor connection	1/2" GAS
10	Oil cooler connection	1/2" NPT
11	Oil drain plug	1/4" NPT
12	Oil drain valve	1/8" NPT
13	Maximum oil temperature sensor	
14	ECO/Liquid injection connection	1-1/8"
SV	Suction valve	4-1/8" - 105 mm
DV	Discharge valve	DN80
SL	Suction line	4-1/8"
V1	Capacity control valve	
V2	Capacity control valve	
V3	Capacity control valve	

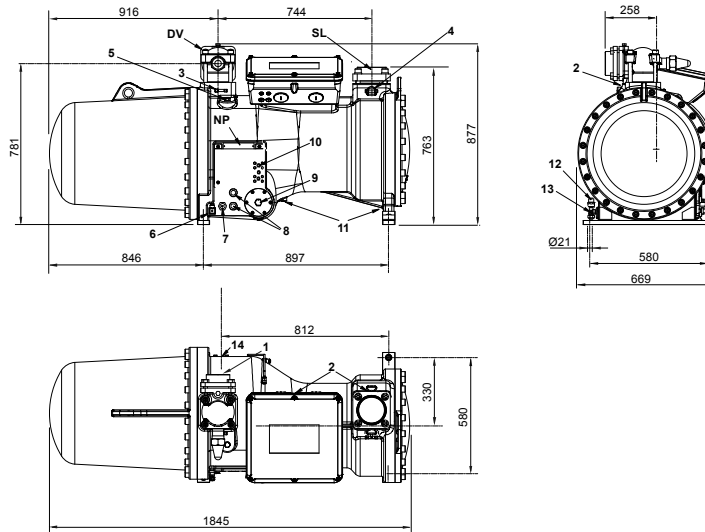

STANDARD

WITH AXIAL SUCTION

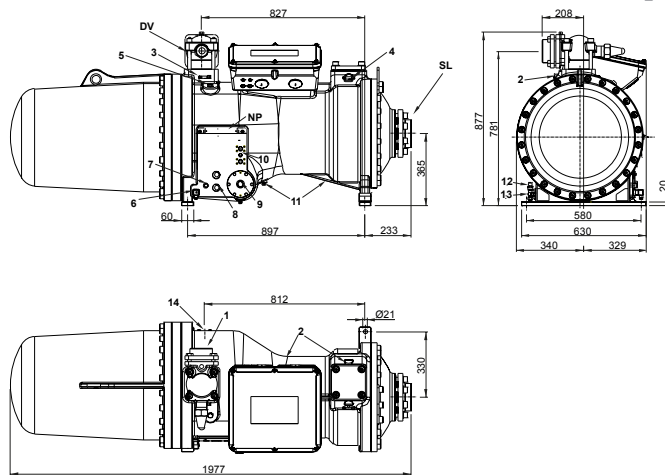

1	High pressure connection	1/8" NPT
2	Low pressure connection	1/8" NPT
3	High pressure connection	1/4" SAE x 1/4" SAE
4	Low pressure connection	1/4" SAE x 1/4" SAE
5	Oil charge plug	3/8" GAS
6	Crankcase heater	
7	Oil level regulator connection	3/4" NPT
8	Oil level sight glass	
9	Filter clogging sensor connection	1/2" GAS
10	Oil cooler connection	1/2" NPT
11	Oil drain plug	1/4" NPT
12	Oil drain valve	1/8" NPT
13	Maximum oil temperature sensor	
14	ECO/Liquid injection connection	1-1/8"
SV	Suction valve	DN125
DV	Discharge valve	4-1/8" - 105 mm
SL	Suction line	DN125
V1	Capacity control valve	
V2	Capacity control valve	
V3	Capacity control valve	

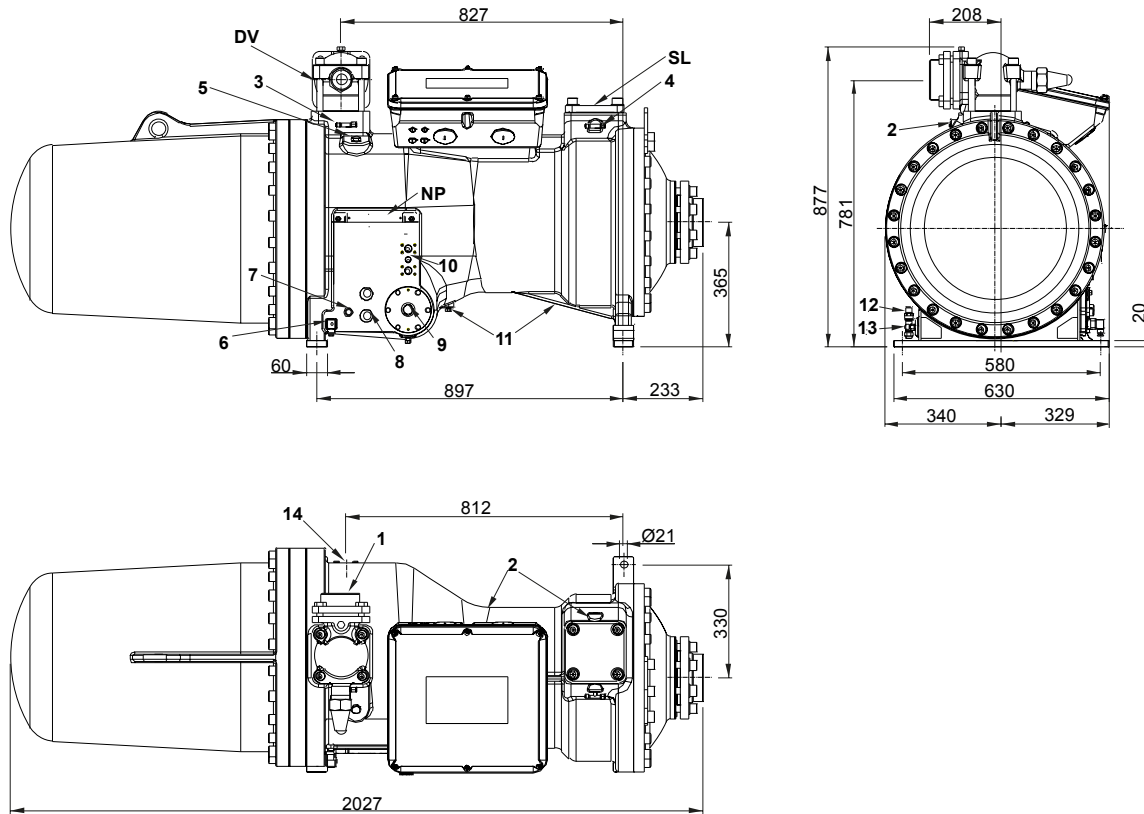

1	High pressure connection	1/8" NPT
2	Low pressure connection	1/8" NPT
3	High pressure connection	1/4" SAE x 1/4" SAE
4	Low pressure connection	1/4" SAE x 1/4" SAE
5	Oil charge plug	3/8" GAS
6	Crankcase heater	
7	Oil level regulator connection	3/4" NPT
8	Oil level sight glass	
9	Filter clogging sensor connection	1/2" GAS
10	Oil cooler connection	1/2" NPT
11	Oil drain plug	1/4" NPT
12	Oil drain valve	1/8" NPT
13	Maximum oil temperature sensor	
14	ECO/Liquid injection connection	1-1/8"
SV	Suction valve	DN125
DV	Discharge valve	4-1/8" - 105 mm
SL	Suction line	DN125
V1	Capacity control valve	
V2	Capacity control valve	
V3	Capacity control valve	

● Around the world

CONTACT & SUBSIDIARIES



HEADQUARTER & PRODUCTION PLANT

FRASCOLD SPA - ITALY, MILAN

Via B. Melzi 105, 20027 Rescaldina (MI) Italy
Tel. +39 0331 742201 - Fax +39 0331 576102
frascold@frascold.it
www.frascold.it

COMMERCIAL OFFICE

FRASCOLD CHINA

Frascold Refrigeration Co. Ltd
Room 226, Block 3, 2nd floor, Enjoy Wise
Park, No. 909, Tianyaoqiao road,
Xuhui District, Shanghai - China
Ph. +86 021 58650180 / 58650192
frascold.china@frascold.net
www.frascold.net

FRASCOLD USA

5343 Bowden Road, Suite 2
Jacksonville, FL 32216 - USA
Ph. +1 (855) 547 5600 Office
info@frascoldusa.com
www.frascoldusa.com

FRASCOLD INDIA PVT LTD

Frascold India Pvt Ltd.
A1/2/14/15, Gallops Industrial Park,
NH-8A, Sarkhej-Bavla Road, Rajoda,
Ahmedabad 382220 Gujarat - India
Ph: +91 2717 685858
sales@frascoldindia.com
www.frascoldindia.com

FRASCOLD VIETNAM

Frascold Vietnam Co. Ltd
Unit 701, 7th floor, 5 Hoang Van Thai street,
Tan Phu Ward, 07 District,
Ho Chi Minh City - Vietnam
Ph: +84 028 54117375
frascold.china@frascold.net
www.frascold.net

DEDICATED PRODUCTIONS FOR LOCAL MARKETS

CHINA - FVR PRODUCTION PLANT

Frascold refrigeration equipment Co. Ltd
Block 10, Phase 3 of the Standard Building
in the General Free Trade Zone
no. 88 Weichuang road,
Taizhou city of Jiangsu province - China

INDIA - CDU ASSEMBLY PLANT

Frascold India Pvt Ltd.
A1/2/15/16 Gallops Industrial Park,
NH-8A, Sarkhej-Bavla Rd, Rajoda,
Ahmedabad 382220 Gujarat - India





We make
temperature