

50 Hz & 60 Hz ●

FVR SERIES

SEMI-HERMETIC SCREW
COMPRESSORS



富士豪[®]
FRASCOLD SPA

FVR SERIES

SEMI-HERMETIC SCREW
COMPRESSORS



INDEX

Product information

Features & Benefits

Conformity Declaration

Performance Data FSS3 Software

ATEX Certification

Capacity

Product Range

Model Designation

Information Plate

Standard Equipment and Optional Accessories

Control Protection Device

Capacity Regulation

Technical Data

Operating Limits

Technical drawings and Dimensions

Oil Injection Kit

Contact & Subsidiaries



● Product Information

FVR H/L SEMI-HERMETIC SCREW COMPRESSORS

The FVR-H and FVR-L Series screw compressors are the result of our many years of experience in building quiet, efficient and reliable compressors.

The FVR Series consists of **45 models** from 30 to 300 Hp and with displacements from 120 to 910 m³/h, and is compatible with **natural and synthetic refrigerants**.

This series is ideal for many uses including industrial, pharmaceutical, retail, marine and heat pump applications.

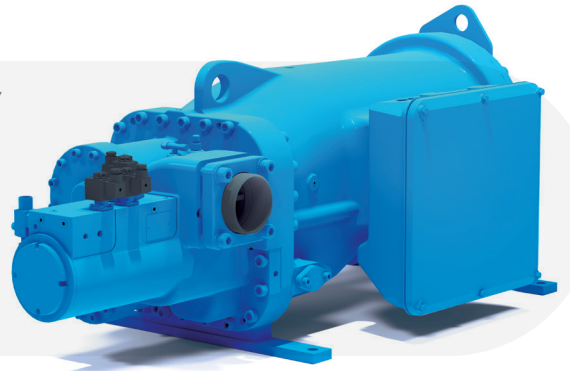

● Product Information

4

FEATURES & BENEFITS



MAXIMUM EFFICIENCY AND RELIABILITY



LOW ENVIRONMENTAL IMPACT



COMPACT AND SILENT DESIGN



VERSATILITY OF USE

CONFORMITY DECLARATION

Frascold screw compressors are intended for installation in refrigeration systems.

The machine or partly completed machines shall comply with local safety regulation and standards of the place of installation (**within the EU according to the EU Directives 2006/42/EC Machinery Directive, 2014/68/EU Pressure Equipment, 2006/95/EC Low Voltage Directive**).

The compressor may be put into operation only if it has been installed in accordance with the assembly instructions provided in the installation manual. Commissioning is only possible if the entire system in which it is integrated has been tested and approved in accordance with legal requirements.

The standards applied are described within the manufacturer's declaration of incorporation, according to the Directive 2006/42/EC, available at: www.frascold.it

PERFORMANCE DATA - FSS3 SOFTWARE

Please refer to our FSS3 Frascold Selection Software to check the performance of all our compressors.



OPERATING LIMITS



TECHNICAL INFORMATION



COOLING CAPACITY



DRAWINGS



ALL OPERATING DATA WITH ANY KIND OF REFRIGERANT



MANUALS



EUROPEAN STANDARD EN12900 AT 50Hz



CATALOGUES AND CERTIFICATIONS

ATEX CERTIFICATION

The ATEX Directive (2014/34 / EU) is a certification for equipment and protective systems intended for use in potentially explosive atmospheres caused by the presence of solid dust gas.

Our range of FVR screw compressors are ATEX certified in category 3G: protective equipment or systems that provide a very high level of protection Zone 2, an area where an explosive atmosphere may be present, but only in rare cases or for short periods.

The compressor label includes the following ATEX assembly marking, usually placed on the cable box:

CE  II 3G IIB T3 Gc -20°C < Ta < 60°C

II: Group 2: Surface industries

3: Category 3 (Zone 2)

G: Use in an explosive atmosphere

IIB: Use with gas group IIB

Ta: Ambient temperature range

Gc: Equipment Protection Level

T3: T3 Category temperature (200°C)



CAPACITY



LEGAL DISCLAIMER: While Frascold has made every effort at the time of publication to ensure the accuracy of the information provided herein, product specifications and performances could be subject to change without notice. You can find the most updated information in our Frascold Selection Software FSS3 at the link: <https://www.frascold.it/en/software>

HEAT PUMPS

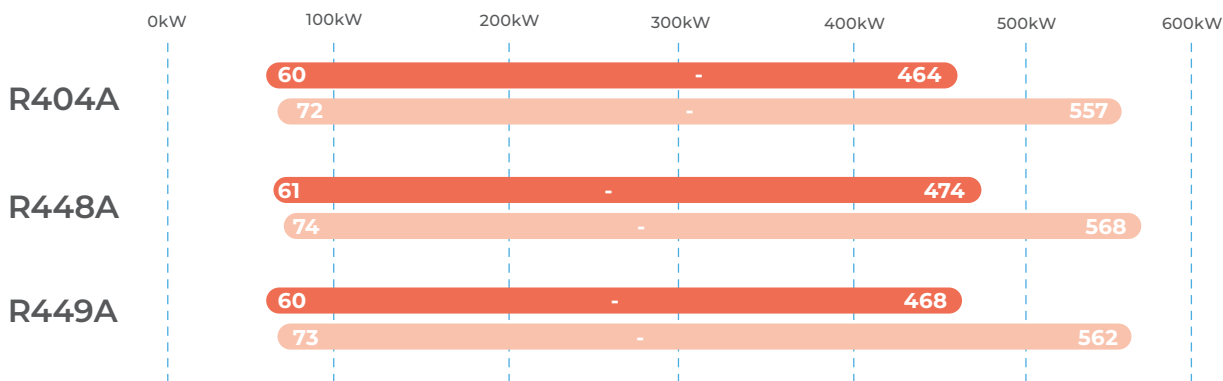

HIGH TEMPERATURE
@ -10/+45° C

DISPLACEMENT
Range @50Hz | @60Hz

CHILLER

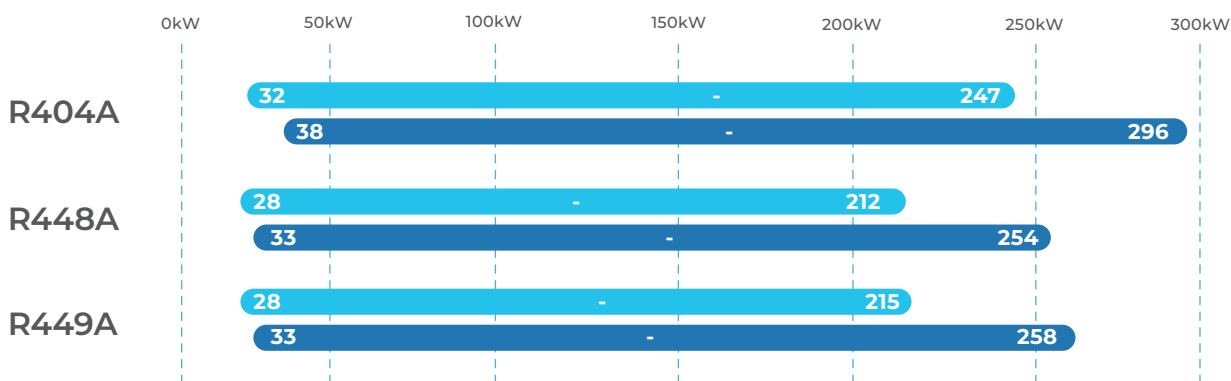

LOW TEMPERATURE
@ -35/+40° C ECO

DISPLACEMENT
Range @50Hz | @60Hz

PRODUCT RANGE

FVR-H SEMI-HERMETIC SCREW COMPRESSORS

SIZE
1

6 Models

30 - 60 HP

120 - 160 m³/h @50Hz

144 - 192 m³/h @60Hz

SIZE
2

6 Models

60 - 90 HP

200 - 270 m³/h @50Hz

240 - 324 m³/h @60Hz

SIZE
3

6 Models

90 - 125 HP

300 - 380 m³/h @50Hz

360 - 456 m³/h @60Hz

SIZE
4

8 Models

110 - 180 HP

370 - 540 m³/h @50Hz

444 - 648 m³/h @60Hz

SIZE
5

6 Models

210 - 300 HP

620 - 912 m³/h @50Hz

744 - 1094.4 m³/h @60Hz

PRODUCT RANGE

FVR-L SEMI-HERMETIC SCREW COMPRESSORS

SIZE
1

3 Models

30 - 50 HP
120 - 160 m³/h @50Hz
144 - 192 m³/h @60Hz

SIZE
2

3 Models

60 - 80 HP
200 - 270 m³/h @50Hz
240 - 324 m³/h @60Hz

SIZE
3

3 Models

90 - 110 HP
300 - 380 m³/h @50Hz
360 - 456 m³/h @60Hz

SIZE
4

2 Models

125 - 160 HP
430 - 540 m³/h @50Hz
516 - 648 m³/h @60Hz

SIZE
5

4 Models

180 - 280 HP
620 - 912 m³/h @50Hz
744 - 1094.4 m³/h @60Hz

MODEL DESIGNATION

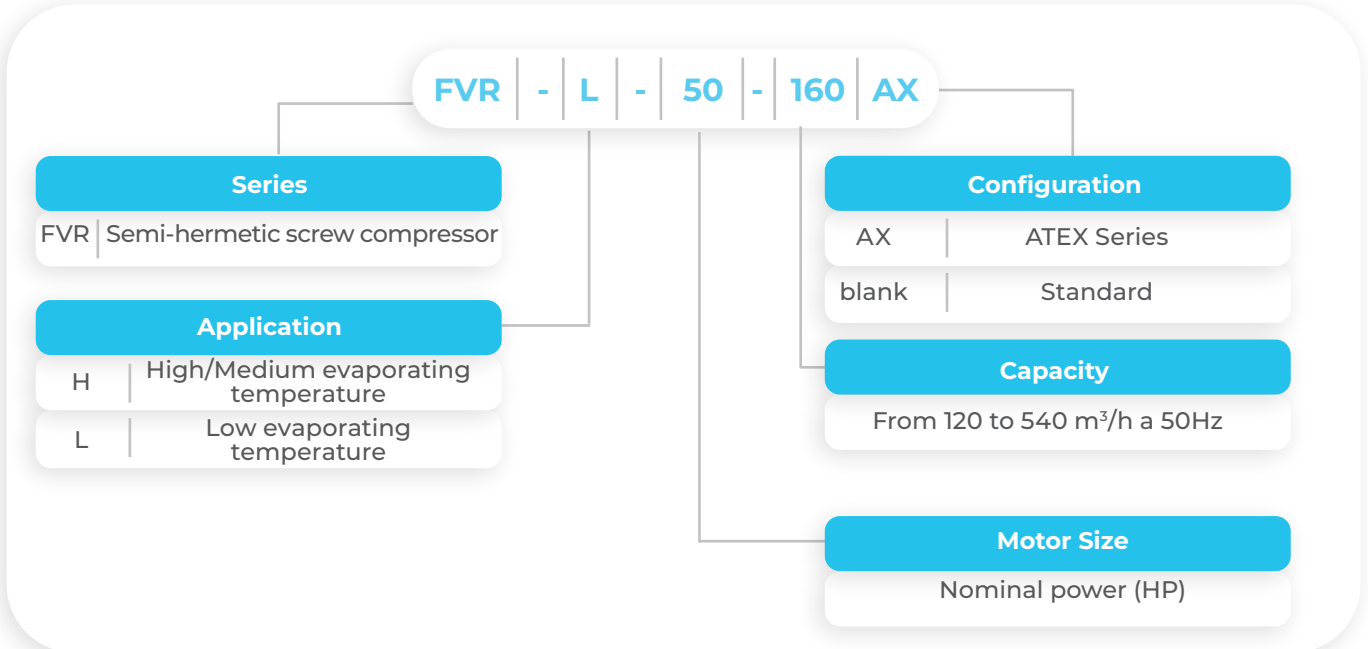

INFORMATION PLATE

All the important information to identify the compressor is displayed on the nameplate. The date of production is contained in the serial number. The user is responsible for indicating the refrigerant type.

FRASCOLD SPA Type **FVR-L-50-160AX** ATEX Certification Compressor model

Nr. **8X000001** Serial number **2023** Manufacturing year

Hz	Displ. m ³ /h	RPM	Max. Operating Disch. Pressure	bar
50	160	2900	bar 30	Maximum operating pressure
60	192	3500	bar 20,5	Maximum operating pressure

Max. Static Suct. Pressure bar 20,5

II 3G Ex h IIB T3 Gc UK CAC CE
20°C < Ta < +55°C

Three-phase alternating current Motor type	PW		MRA		PWS		LRA		Locked rotor current
	Volt 3~	Hz	PW	MRA	PWS	DOL	DOL		
Voltage and frequencies	380-420	50	89		220	340	340	PWS locked rotor current	
	440-480	60	89		220	340	340	DOL locked rotor current	

Maximum operating current

Identification code: **CFL051608XX000001** Place of manufacturing: **MADE IN ITALY**

STANDARD EQUIPMENT AND OPTIONAL ACCESSORIES



Description	FVR	
	Std.	Opt.
Part winding (PWS) electric motor 380-420 V / 3 / 50 Hz (440-480 V / 3 / 60 Hz)	■	
Suction shut-off valves with soldering connections [OPT for FVR H / L 620 - 700 - 810 - 910]	■	
Suction flanges with soldering connections [FVR H / L 620 - 700 - 810 - 910]	■	
Discharge shut-off valves with soldering connections		■
Discharge flanges with soldering connections	■	
Integrated check valve and safety valve	■	
Steps capacity control and unloaded start	■	
IP65 terminal box	■	
Discharge temperature PTC sensor	■	
INT69 FRY electronic protection module with manual reset	■	
Rotalock connection for oil injection	■	
Integrated oil filter and oil flow switch [FVR H/L 370 - 430 - 460 - 540]	■	
Oil injection kit: oil filter, oil flow switch, solenoid valve, oil sight glass [FVR]	■	
Oil injection kit: solenoid valve, oil sight glass [FVR H / L 370 - 430 - 460 - 540]	■	
Nitrogen protective charge	■	
Packing ensuring proper handling and adequate protection	■	
Special voltage for electric motor		■
Rubber vibration dampers (4 pcs)		■
Valve connection kit for ECO		■
Electronic Alarm Control Module for oil flow switch		■
Oil Filter Clogging Differential Pressure Switch (Electronic)		■
Bridges for DOL Start (STD for FVR H/L 120-140-160)		■
Special painting		■
INT69 FRYL Diagnose electronic protection module		■

- Standard
- Optional

CAPACITY REGULATION

Frascold Screw compressors capacity can be regulated with:

1 CAPACITY CONTROL (CC)

2 VARIABLE FREQUENCY DRIVE (VFD)

1 CAPACITY CONTROL (CC)

Under conditions of reduced heat load, the compressor is able to bring the system to the correct temperature in less time. Thanks to capacity control, the number of starts/stops is reduced, allowing greater efficiency and greater reliability for the entire system.

	STOP
FVR 120-160	75 / 100%
FVR 200-540	50 / 75 / 100%

Solenoid activation diagram

Capacity control ⁽¹⁾

Model series	Full load(100%)	1. Step (75%)	2. Step (50%)	Start/Stop ⁽²⁾
FVR-H/L 120-140-160	V1= ●	V1= ○	-	-
FVR-H/L 200-230-260 FVR-H/L 300-350-380	V1= ● V2= ●	V1= ● V2= ○	V1= ○ V2= ○	-
FVR-H/L 370-430-460-540	V1= ● V2= ○ V3= ○	V1= ● V2= ○ V3= ●	V1= ● V2= ● V3= ○	V1= ○ V2= ○ V3= ○
FVR-H/L 620-700-810-910	V1= ① V2= ○ V3= ○ V4= ○	V1= ① V2= ○ V3= ● V4= ○	V1= ① V2= ● V3= ○ V4= ○	V1= ○ V2= ○ V3= ○ V4= ●

1: The effective capacity of the stages depends on the operating conditions.
2: The start/stop step can only be used during the start-up and stopping phases.

- Coil de-energized
- Coil energized
- ① Coil 4s energized and 20s de-energized alternately

2 VARIABLE FREQUENCY DRIVE (VFD)

All compressors are designed to be compatible with inverter technology and are suitable for operation in the frequency range (30÷70 Hz). Under certain operating conditions, a restriction on the range of frequency. In particular, the maximum frequency depends on the maximum operating current (MRA). For performance data at the various frequencies and the maximum limits in each condition see the Frascold Selection Software.

Calculate the maximum frequency

Within the operating limits of each specific compressor and refrigerant for each point of work, there is a maximum frequency not to exceed, which can be calculated using the following formula:

f(Max) = maximum possible frequency [Hz]
MRA = maximum operational current [A]
Ie = current absorbed at the work point at 50 Hz [A]

$$f(\text{Max}) = \frac{\text{MRA} \times 50 \text{ Hz}}{I_e}$$

Calculate the corresponding capacity

The cooling capacity is calculated as a function of the frequency using the following formula:

Q0 (f) = refrigeration capacity at working frequency [W]
fa = actual frequency applied to the compressor [Hz]
Q0 50 Hz = refrigeration capacity at 50 Hz [W]

$$Q_0(f) = \frac{f_a \times Q_0 \text{ 50 Hz}}{50 \text{ Hz}}$$

● Technical data and operating limits

Motor power supply PWS 400 (+/-10%) V/3/50Hz // 460 (+/-10%) V/3/60Hz

Models	Motor version	Displacement		Nominal power 50Hz	Capacity control	MRA	LRA, PWS motor	LRA, DOL motor	Frequency min.	Frequency max.
		50Hz	60Hz							
		m ³ /h		[HP]	[%]	[A]	[A]	[A]	[Hz]	[Hz]
FVR-H-30-120	3	120	144	30	75%	61	125	216	30	70
FVR-H-40-140	3	140	168	40	75%	68	171	294	30	70
FVR-H-50-160	3	160	192	50	75%	89	220	340	30	70
FVR-H-60-200	3	200	240	60	75% - 50%	108	262	425	30	70
FVR-H-70-230	3	230	276	70	75% - 50%	128	298	518	30	70
FVR-H-80-270	3	270	324	80	75% - 50%	145	373	600	30	70
FVR-H-90-300	3	300	360	90	75% - 50%	163	405	649	30	70
FVR-H-100-350	3	350	420	100	75% - 50%	183	488	767	30	70
FVR-H-110-370	3	370	444	110	75% - 50%	154	434	720	30	70
FVR-H-110-380	3	380	456	110	75% - 50%	211	505	793	30	70
FVR-H-115-430	3	430	516	115	75% - 50%	184	434	720	30	70
FVR-H-125-460	3	460	552	125	75% - 50%	218	530	838	30	70
FVR-H-140-540	3	540	648	140	75% - 50%	245	587	921	30	70
FVR-H-40-120	1	120	144	40	75%	68	171	294	30	70
FVR-H-50-140	1	140	168	50	75%	89	220	340	30	70
FVR-H-60-160	1	160	192	60	75%	108	262	425	30	70
FVR-H-70-200	1	200	240	70	75% - 50%	128	298	518	30	70
FVR-H-80-230	1	230	276	80	75% - 50%	145	373	600	30	70
FVR-H-90-270	1	270	312	90	75% - 50%	163	405	649	30	70
FVR-H-100-300	1	300	360	100	75% - 50%	183	488	767	30	70
FVR-H-115-350	1	350	420	115	75% - 50%	211	505	793	30	70
FVR-H-125-370	1	370	444	125	75% - 50%	218	530	838	30	70
FVR-H-125-380	1	380	456	125	75% - 50%	226	560	880	30	70
FVR-H-140-430	1	430	516	140	75% - 50%	245	587	921	30	70
FVR-H-160-460	1	460	552	160	75% - 50%	282	729	1114	30	70
FVR-H-180-540	1	540	648	180	75% - 50%	304	786	1209	30	70
FVR-H-210-620	1	620	744	210	75%-50%	375	465	1442	30	70
FVR-H-240-700	1	700	840	240	75%-50%	434	586	1853	30	70
FVR-H-280-810	1	810	972	280	75%-50%	474	650	2029	30	70
FVR-H-300-910	1	910	1092	300	75%-50%	492	805	2520	30	70
FVR-L-30-120	2	120	144	30	75%	61	125	216	30	70
FVR-L-40-140	2	140	168	40	75%	68	171	294	30	70
FVR-L-50-160	2	160	192	50	75%	89	220	340	30	70
FVR-L-60-200	2	200	240	60	75% - 50%	108	262	425	30	70
FVR-L-70-230	2	230	276	70	75% - 50%	128	298	518	30	70
FVR-L-80-270	2	270	312	80	75% - 50%	145	373	600	30	70
FVR-L-90-300	2	300	360	90	75% - 50%	163	405	649	30	70
FVR-L-100-350	2	350	420	100	75% - 50%	183	488	767	30	70
FVR-L-110-380	2	380	456	110	75% - 50%	211	505	793	30	70
FVR-L-125-430	2	430	516	125	75% - 50%	218	530	838	30	70
FVR-L-160-540	2	540	648	160	75% - 50%	287	729	1114	30	70
FVR-L-180-620	2	620	744	180	75%-50%	333	436	1364	30	70
FVR-L-200-700	2	700	840	200	75%-50%	368	465	1442	30	70
FVR-L-240-810	2	810	972	240	75%-50%	434	586	1853	30	70
FVR-L-280-910	2	910	1092	265	75%-50%	492	650	2029	30	70

LEGAL DISCLAIMER:

While Frascold has made every effort at the time of publication to ensure the accuracy of the information provided herein, product specifications and performances could be subject to change without notice. You can find the most updated information in our Product Selection Software FSS3 at the link: <https://www.frascold.it/en/software>

● Technical data and operating limits

Motor power supply PWS 400 (+/-10%) V/3/50Hz // 460 (+/-10%) V/3/60Hz

Models	Protection index	Maximum standstill pressure	Maximum operative pressure	Suction valve (SV)		Discharge Line (DL)		Net weight
		[bar]	[bar]	[mm]	[Inch]	[mm]	[Inch]	[Kg]
FVR-H-30-120	IP65	20.5	30	54	2" 1/8	42	1" 5/8	210
FVR-H-40-140	IP65	20.5	30	54	2" 1/8	42	1" 5/8	223
FVR-H-50-160	IP65	20.5	30	54	2" 1/8	42	1" 5/8	223
FVR-H-60-200	IP65	20.5	30	80	-	54	2" 1/8	324
FVR-H-70-230	IP65	20.5	30	80	-	54	2" 1/8	339
FVR-H-80-270	IP65	20.5	30	80	-	54	2" 1/8	352
FVR-H-90-300	IP65	20.5	30	80	-	67	-	430
FVR-H-100-350	IP65	20.5	30	80	-	67	-	432
FVR-H-110-370	IP65	20.5	30	105	4 1/8"	DN80	-	711
FVR-H-110-380	IP65	20.5	30	80	-	67	-	435
FVR-H-115-430	IP65	20.5	30	105	4 1/8"	DN80	-	732
FVR-H-125-460	IP65	20.5	30	105	4 1/8"	DN80	-	735
FVR-H-140-540	IP65	20.5	30	105	4 1/8"	DN80	-	749
FVR-H-40-120	IP65	20.5	30	54	2" 1/8	42	1" 5/8	215
FVR-H-50-140	IP65	20.5	30	54	2" 1/8	42	1" 5/8	223
FVR-H-60-160	IP65	20.5	30	54	2" 1/8	42	1" 5/8	226
FVR-H-70-200	IP65	20.5	30	80	-	54	2" 1/8	326
FVR-H-80-230	IP65	20.5	30	80	-	54	2" 1/8	341
FVR-H-90-270	IP65	20.5	30	80	-	54	2" 1/8	354
FVR-H-100-300	IP65	20.5	30	80	-	67	-	432
FVR-H-115-350	IP65	20.5	30	80	-	67	-	434
FVR-H-125-370	IP65	20.5	30	105	4 1/8"	DN80	-	734
FVR-H-125-380	IP65	20.5	30	80	-	67	-	437
FVR-H-140-430	IP65	20.5	30	105	4 1/8"	DN80	-	742
FVR-H-160-460	IP65	20.5	30	105	4 1/8"	DN80	-	749
FVR-H-180-540	IP65	20.5	30	105	4 1/8"	DN80	-	765
FVR-H-210-620	IP65	20.5	30	105	4 1/8"	DN80	-	903
FVR-H-240-700	IP65	20.5	30	105	4 1/8"	DN80	-	923
FVR-H-280-810	IP65	20.5	30	DN125	-	105	4 1/8"	950
FVR-H-300-910	IP65	20.5	30	DN125	-	105	4 1/8"	959
FVR-L-30-120	IP65	20.5	30	54	2" 1/8	42	1" 5/8	210
FVR-L-40-140	IP65	20.5	30	54	2" 1/8	42	1" 5/8	218
FVR-L-50-160	IP65	20.5	30	54	2" 1/8	42	1" 5/8	223
FVR-L-60-200	IP65	20.5	30	80	-	54	2" 1/8	324
FVR-L-70-230	IP65	20.5	30	80	-	54	2" 1/8	339
FVR-L-80-270	IP65	20.5	30	80	-	54	2" 1/8	352
FVR-L-90-300	IP65	20.5	30	80	-	67	-	430
FVR-L-100-350	IP65	20.5	30	80	-	67	-	432
FVR-L-110-380	IP65	20.5	30	80	-	67	-	435
FVR-L-125-430	IP65	20.5	30	105	4 1/8"	DN80	-	735
FVR-L-160-540	IP65	20.5	30	105	4 1/8"	DN80	-	762
FVR-L-180-620	IP65	20.5	30	105	4 1/8"	DN80	-	885
FVR-L-200-700	IP65	20.5	30	105	4 1/8"	DN80	-	900
FVR-L-240-810	IP65	20.5	30	DN125	-	105	4 1/8"	925
FVR-L-280-910	IP65	20.5	30	DN125	-	105	4 1/8"	943

OPERATING LIMITS

The schematics published in this catalog are intended as a general schematic for the entire range of FVR semi-hermetic screw compressors. For specific models and refrigerant performance data, use the Frascold Selection Software FSS3, available for free download at www.frascold.it/en. Diagrams assume a full compressor load with a 50 Hz supply frequency.

R134a

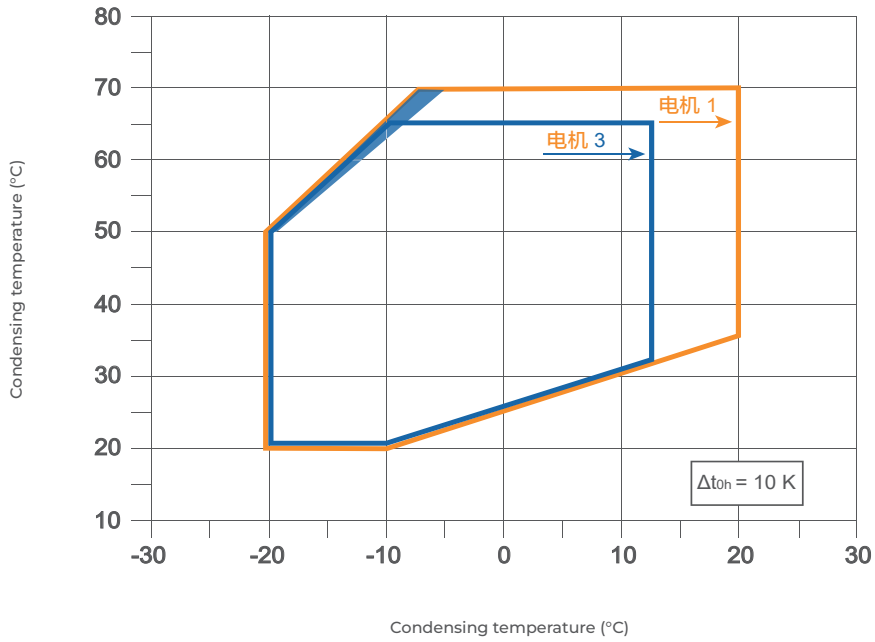

Standard application diagram

Motor size 1 - 2
Compressor capacity 100%
Overheating = 10K

■ For operation in this zone, please contact Frascold.

R404A - R507A

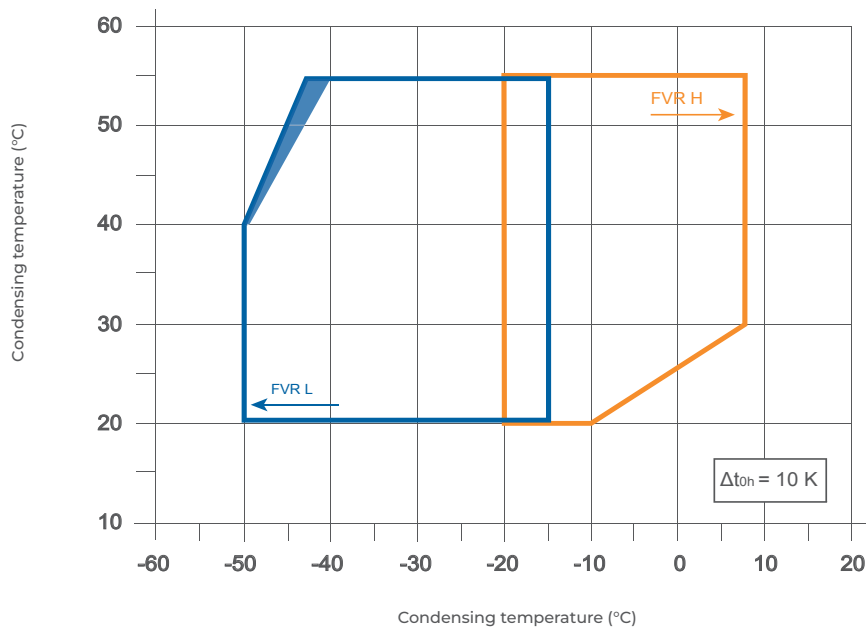

Standard application diagram

FVR H/L
Compressor capacity 100%
Overheating = 10K

■ For operation in this zone, please contact Frascold.



Performance displayed for R134a, R404A, R507A, R448A, R449A, R407F, R407A and R290. Data on other refrigerants are available upon request. Capacities are given in accordance with European standard EN12900 and with 50 Hz operation. To calculate capacities under other conditions and at 60 Hz, use the Frascold Selection Software, which can be downloaded free of charge from <https://www.frascold.it/en/software>

R448A - R449A

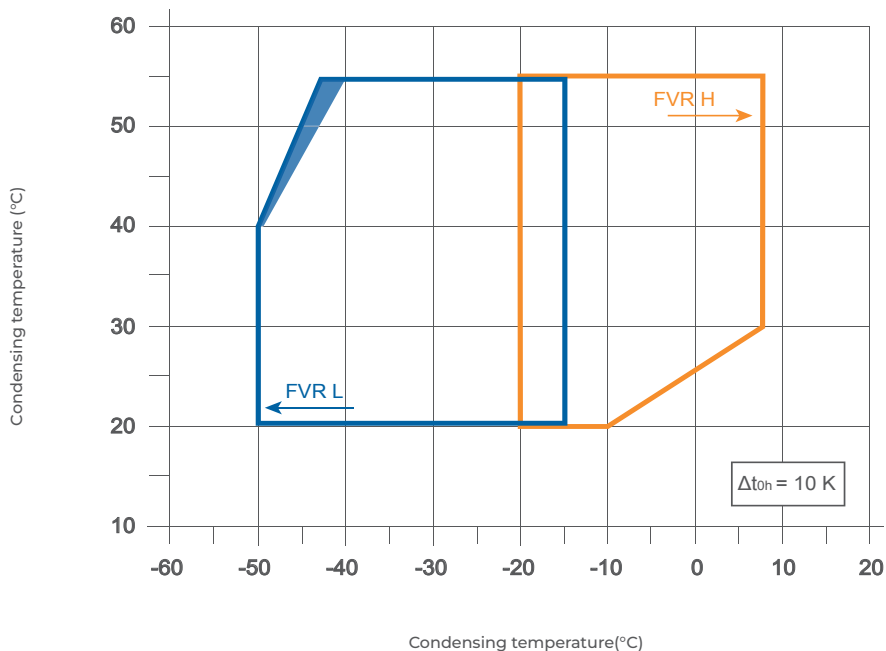

Standard application diagram

FVR H/L

Compressor capacity 100%

Overheating = 10K

■ For operation in this zone, please contact Frascold.

R407F - R407A

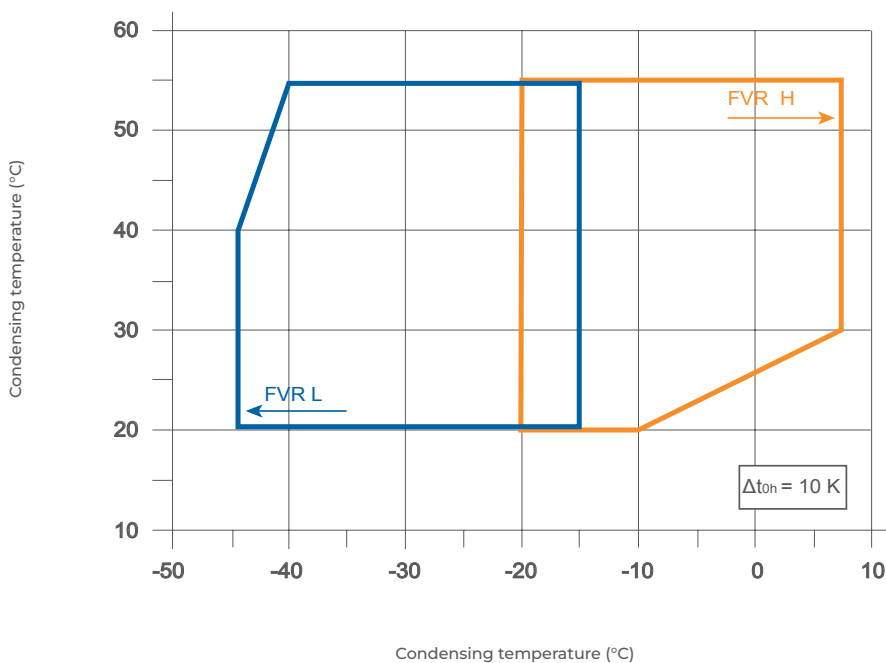

Standard application diagram

FVR H/L

Compressor capacity 100%

Overheating = 10K

R290

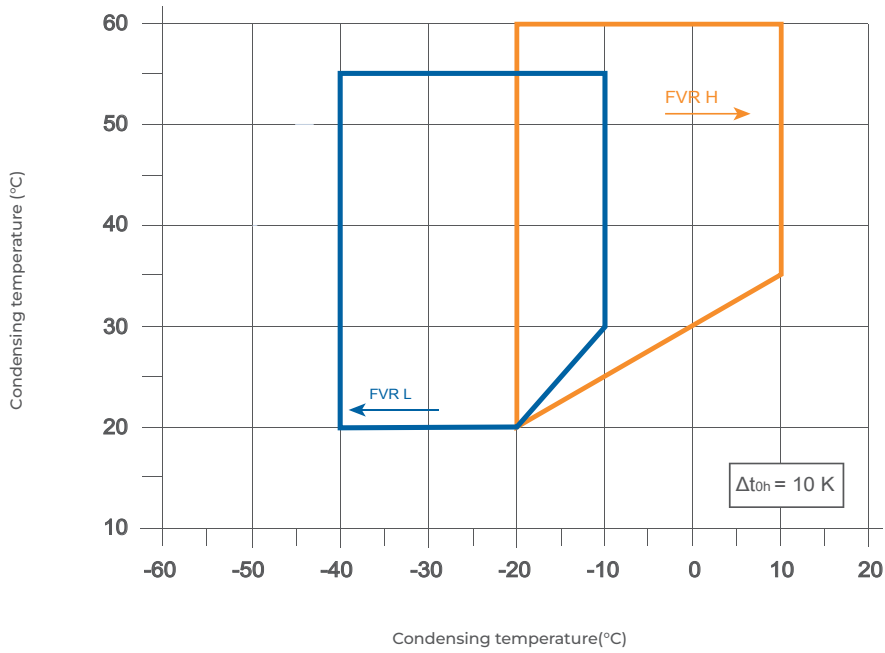

Standard application diagram
FVR H/L
Compressor capacity 100%
Overheating = 10K

LEGAL DISCLAIMER:

While Frascold has made every effort at the time of publication to ensure the accuracy of the information provided herein, product specifications and performances could be subject to change without notice. You can find the most updated information in our Product Selection Software FSS3 at the link: <https://www.frascold.it/en/software>

TECHNICAL DRAWINGS AND DIMENSIONS

FVRH/L 120-140-160

FVRH/L - 120 - 140 - 160

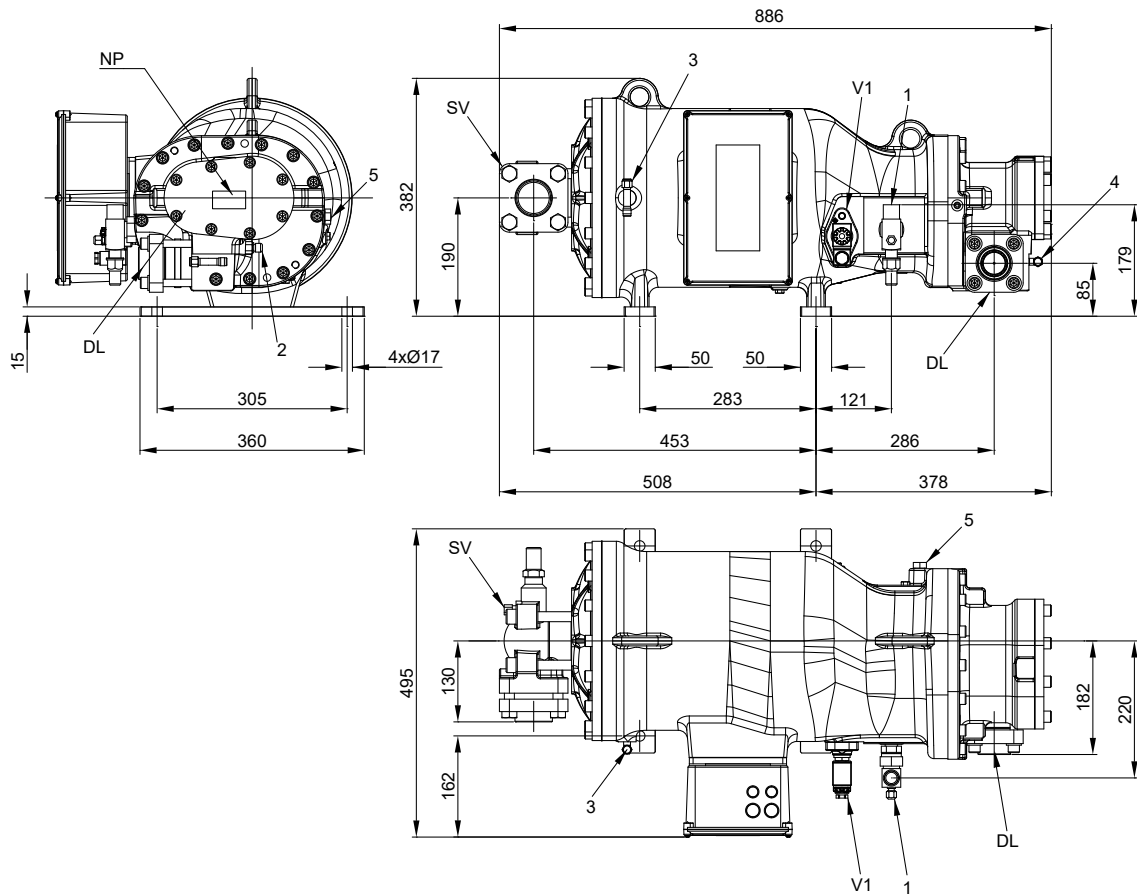

1	Oil return line connection	
2	Discharge temperature sensor	
3	Low pressure connection	
4	High pressure connection	
5	Connection for ECO	1/2" SAE
V1	Capacity control valve (step 1)	
SV	Suction valve	2-1/8" - 54,0 mm
DL	Discharge line	1-5/8" - 42,0 mm
NP	Information plate	

FVRH/L - 200 - 230 - 270

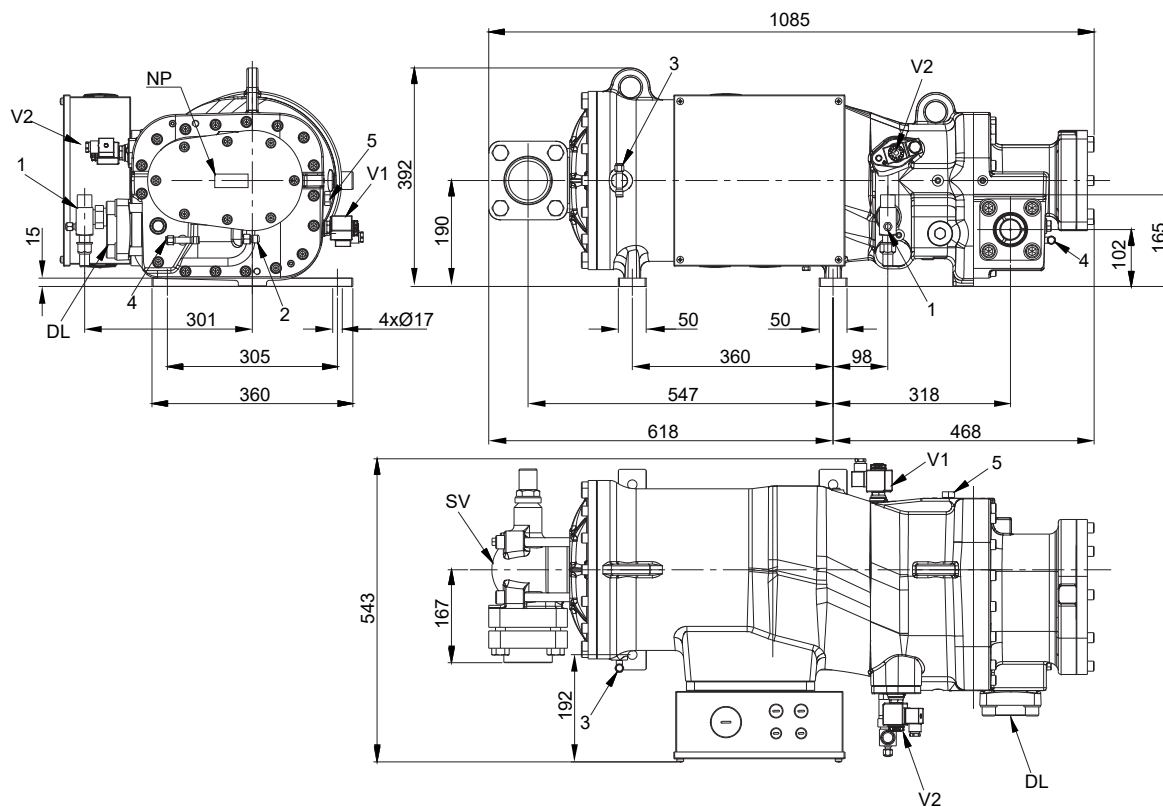

1	Oil return line connection	
2	Discharge temperature sensor	
3	Low pressure connection	
4	High pressure connection	
5	Connection for ECO	
V1	Capacity control valve	
V2	Capacity control valve	
SV	Suction valve	3-1/8" - 80 mm
DL	Discharge line	2-1/8" - 54 mm
NP	Information plate	

FVRH/L - 90 - 270

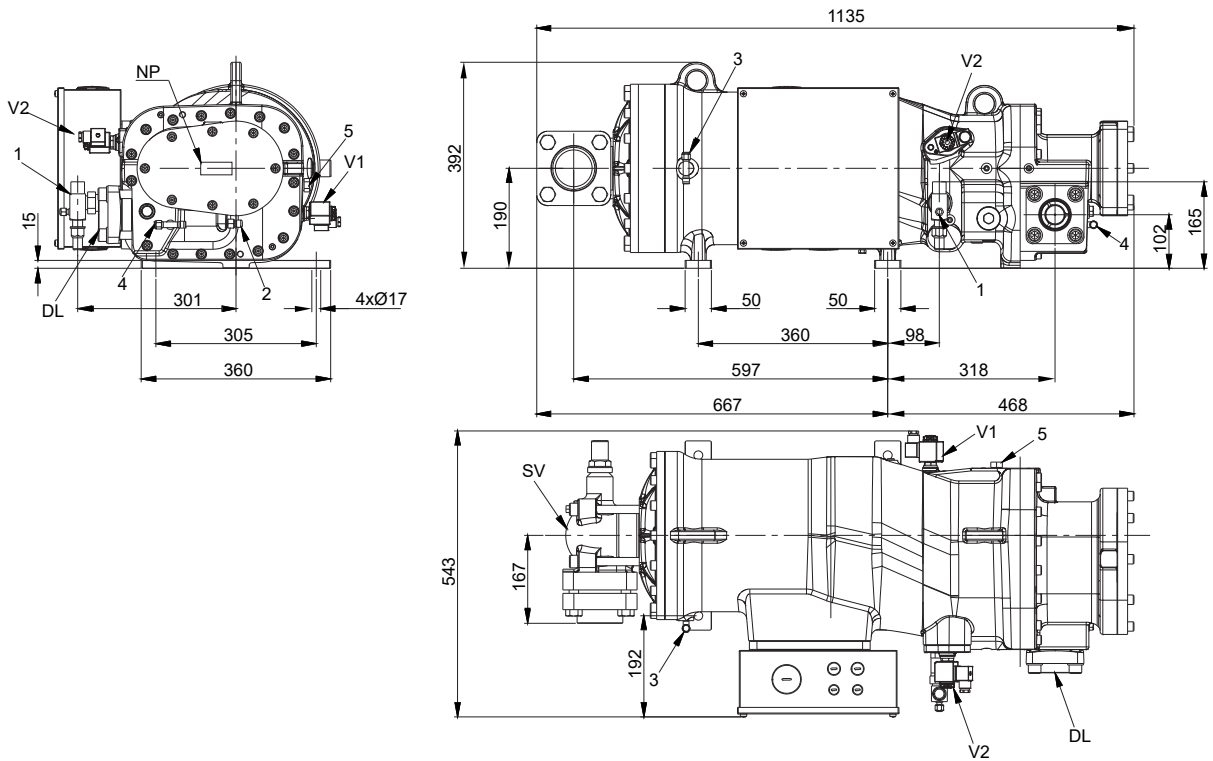

1	Oil return line connection	
2	Discharge temperature sensor	
3	Low pressure connection	
4	High pressure connection	
5	Connection for ECO	
V1	Capacity control valve	
V2	Capacity control valve	
SV	Suction valve	3-1/8" - 80 mm
DL	Discharge line	54 mm
NP	Information plate	

FVRH/L - 300 - 350 - 380

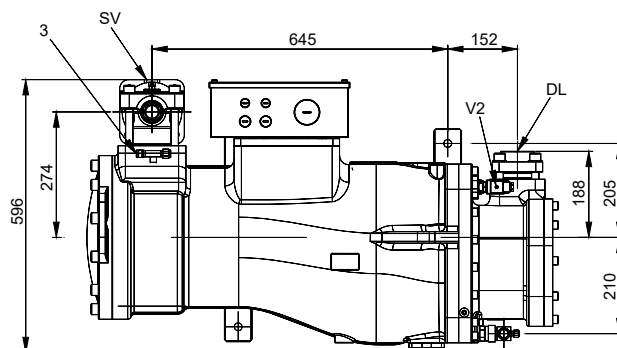
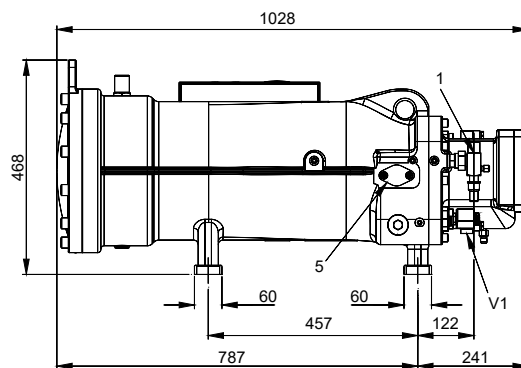
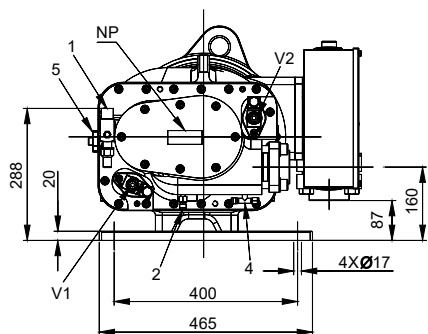

1	Oil return line connection	
2	Discharge temperature sensor	
3	Low pressure connection	
4	High pressure connection	
5	Connection for ECO	
V1	Capacity control valve	
V2	Capacity control valve	
SV	Suction valve	3-1/8" - 80 mm
DL	Discharge line	67 mm
NP	Information plate	

FVRH/L - 370 - 430 - 460 - 540

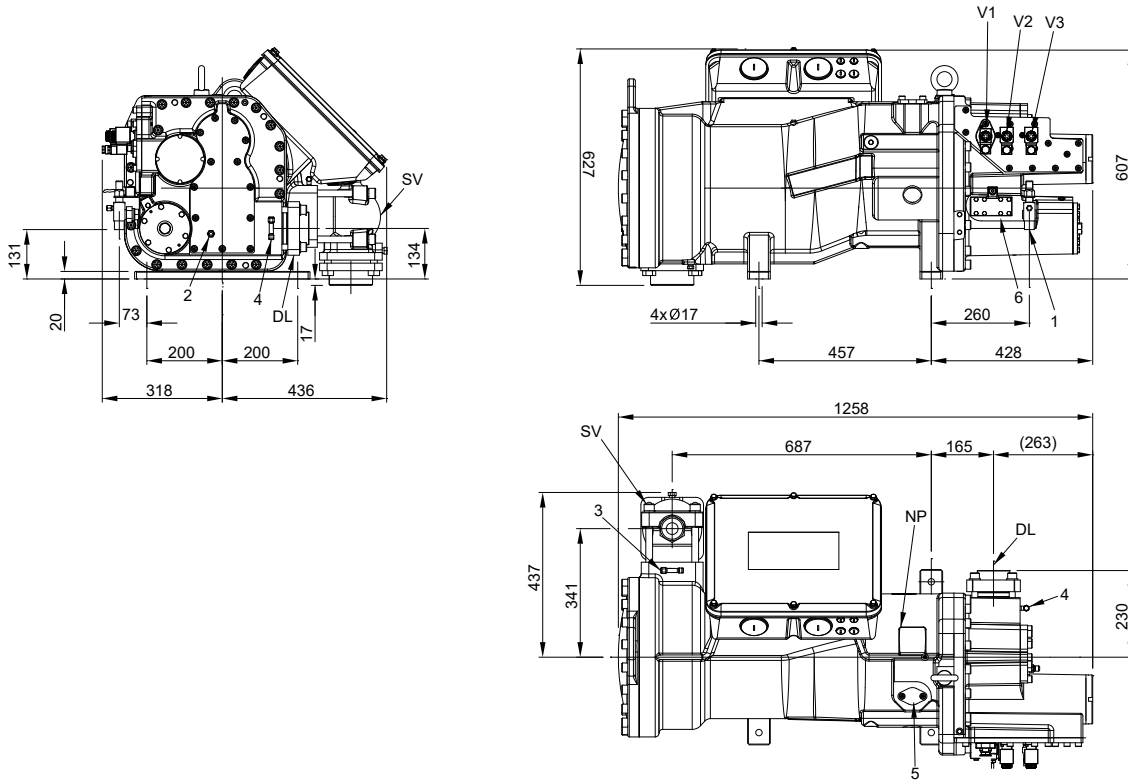

1	Oil return line connection	
2	Discharge temperature sensor	
3	Low pressure connection	
4	High pressure connection	
5	Connection for ECO	
V1	Capacity control valve	
V2	Capacity control valve	
V3	Capacity control valve	
SV	Suction valve	4-1/8" - 105 mm
DL	Discharge line	80 mm
NP	Information plate	

FVRH/L - 810 - 900

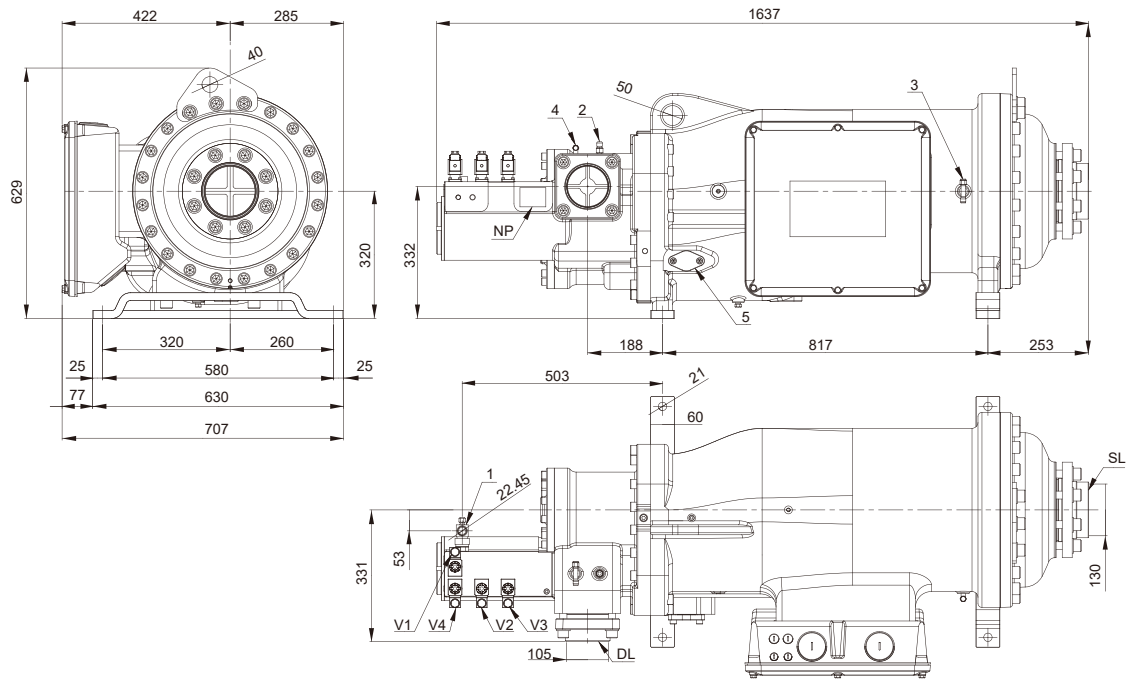

1	Oil return line connection	
2	Discharge temperature sensor	
3	Low pressure connection	
4	High pressure connection	
5	Connection for ECO	
V1	Capacity control valve	
V2	Capacity control valve	
V3	Capacity control valve	
V4	Capacity control valve	
SL	Suction valve	DN125
DL	Discharge line	4-1/8" - 105 mm
NP	Information plate	

OIL INJECTION KIT

The standard Frascold oil injection kit includes:

- Oil filter
- Flowswitch with electronic control module
- Solenoid valve
- Oil flow sight glass

Oil circuit diagram for FVR-H/L-370-430-460-540

In the FVR Models, the flowswitch and the oil filter are integrated with the compressor.

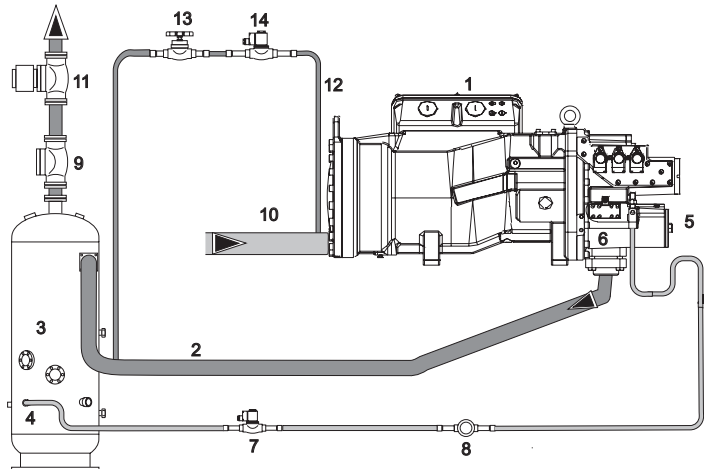

Oil circuit diagram for all other models.

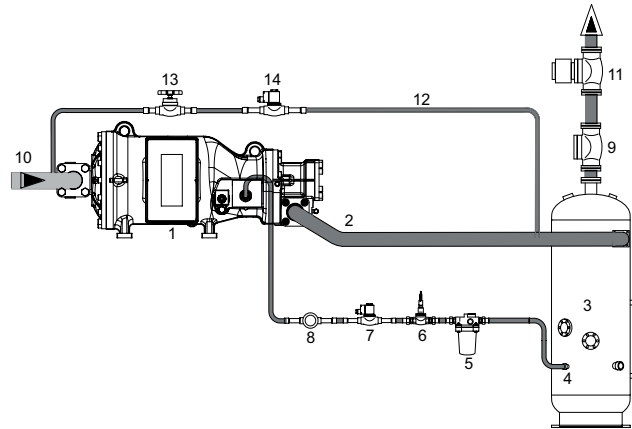

1	Compressor
2	Discharge line
3	Remote oil separator with thermostat, resistance and level detector
4	Oil return line to the compressor
5	Oil filter
6	Oil flowswitch
7	Solenoid valve
8	Oil sight glass
9	Check valve
10	Suction line
11	Discharge pressure regulation valve
12	External equalization line
13	Shut off valve
14	Solenoid valves

CONTACT & SUBSIDIARIES



HEADQUARTER & PRODUCTION PLANT

FRASCOLD SPA - ITALY, MILAN

Via B. Melzi 105, 20027 Rescaldina (MI) Italy
Tel. +39 0331 742201 - Fax +39 0331 576102
frascold@frascold.it
www.frascold.it

COMMERCIAL OFFICE

FRASCOLD CHINA

Frascold Refrigeration Co. Ltd
Room 226, Block 3, 2nd floor, Enjoy Wise
Park, No. 909, Tianyaoqiao road,
Xuhui District, Shanghai - China
Ph. +86 021 58650180 / 58650192
frascold.china@frascold.net
www.frascold.net

FRASCOLD USA

5343 Bowden Road, Suite 2
Jacksonville, FL 32216 - USA
Ph. +1 (855) 547 5600 Office
info@frascoldusa.com
www.frascoldusa.com

FRASCOLD INDIA PVT LTD

Frascold India Pvt Ltd.
A1/2/14/15, Gallops Industrial Park,
NH-8A, Sarkhej-Bavla Road, Rajoda,
Ahmedabad 382220 Gujarat - India
Ph: +91 2717 685858
sales@frascoldindia.com
www.frascoldindia.com

FRASCOLD VIETNAM

Frascold Vietnam Co. Ltd
Unit 701, 7th floor, 5 Hoang Van Thai street,
Tan Phu Ward, 07 District,
Ho Chi Minh City - Vietnam
Ph: +84 028 54117375
frascold.china@frascold.net
www.frascold.net

DEDICATED PRODUCTIONS FOR LOCAL MARKETS

CHINA - FVR PRODUCTION PLANT

Frascold refrigeration equipment Co. Ltd
Block 10, Phase 3 of the Standard Building
in the General Free Trade Zone
no. 88 Weichuang road,
Taizhou city of Jiangsu province - China

INDIA - CDU ASSEMBLY PLANT

Frascold India Pvt Ltd.
A1/2/15/16 Gallops Industrial Park,
NH-8A, Sarkhej-Bavla Rd, Rajoda,
Ahmedabad 382220 Gujarat - India

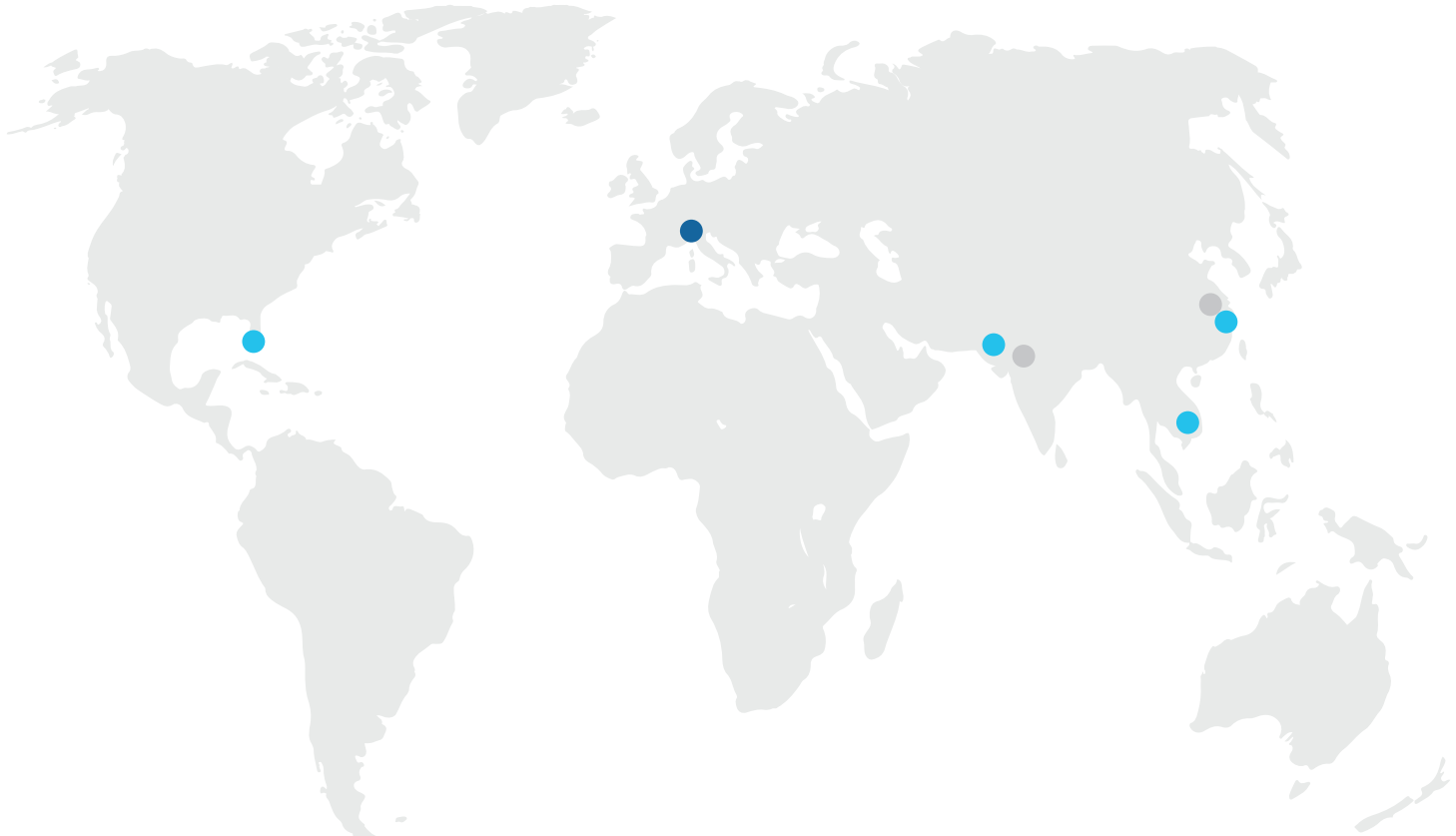

We make
temperature