

50 Hz & 60 Hz ●

STANDARD SERIES

SEMI-HERMETIC RECIPROCATING
COMPRESSORS

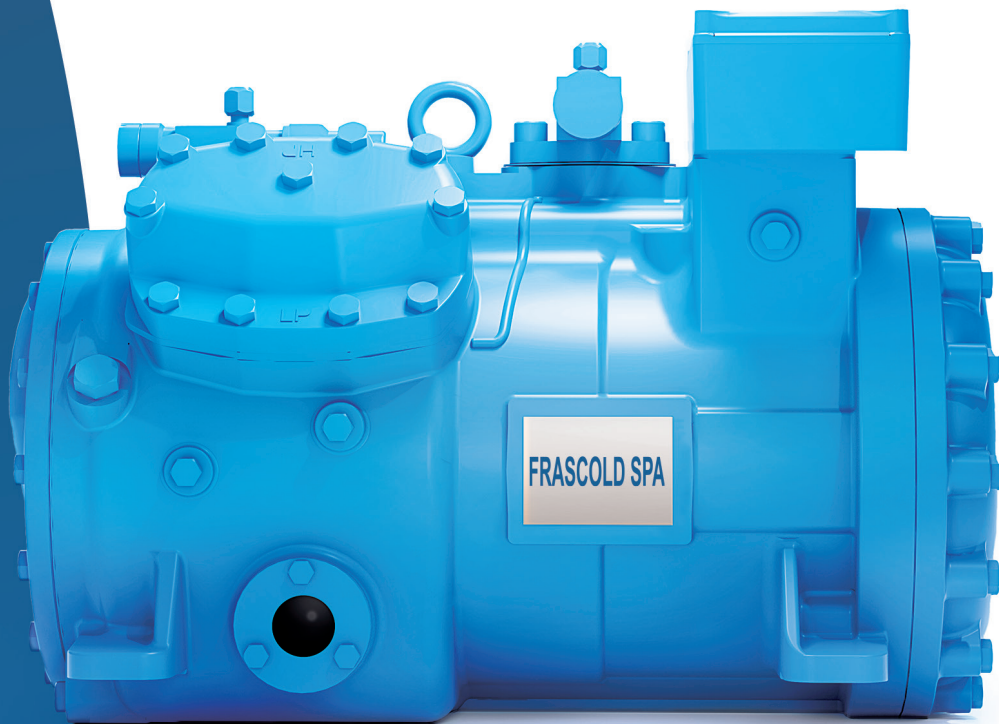

富士豪[®]
FRASCOLD SPA

STANDARD SERIES

**SEMI-HERMETIC RECIPROCATING
COMPRESSORS**



INDEX

Product information

Features & Benefits

Conformity Declaration

Performance Data FSS3 Software

ASERCOM and UL Certification

Capacity

Product Range

Model Designation

Information Plate

Standard Equipment and Optional Accessories

Control Protection Device

Capacity Regulation

Technical Data

Operating Limits

Technical Drawings and Dimensions

Contact & Subsidiaries



● Product information

SEMI-HERMETIC RECIPROCATING COMPRESSORS

Performance, reliability and efficiency: those are the 3 key words when it comes to Frascold's range of semi-hermetic reciprocating compressors. The Standard series consists **of 8 sizes, with 84 models** from **0.5 to 80 HP**, with the option of being powered by an inverter.

Models D, Q, S, V, Z & W are also compatible with our revolutionary **capacity control system and RSH.**



● Product information

4 FEATURES & BENEFITS



OPTIMIZED DESIGN



RELIABILITY



QUIETNESS



HIGH EFFICIENCY



FLEXIBILITY

CONFORMITY DECLARATION

Frascold reciprocating compressors are intended for installation in refrigeration systems.

The machine or partly completed machines shall comply with local safety regulation and standards of the place of installation (**within the EU according to the EU Directives 2006/42/EC Machinery Directive, 2014/68/EU Pressure Equipment, 2006/95/EC Low Voltage Directive**).

The compressor may be put into operation only if it has been installed in accordance with the assembly instructions provided in the installation manual.

Commissioning is only possible if the entire system in which it is integrated has been tested and approved in accordance with legal requirements.

The standards applied are described within the manufacturer's declaration of incorporation, according to the Directive 2006/42/EC, available at: www.frascold.it

PERFORMANCE DATA - FSS3 SOFTWARE

Please refer to our FSS3 Frascold Selection Software to check the performance of all our compressors.



OPERATING LIMITS



TECHNICAL INFORMATION



COOLING CAPACITY



DRAWINGS



ALL OPERATING DATA WITH ANY KIND OF REFRIGERANT



MANUALS



EUROPEAN STANDARD EN12900 AT 50Hz



CATALOGUES AND CERTIFICATIONS

ASERCOM CERTIFICATION

What is ASERCOM

ASERCOM (Association of European Refrigeration Component Manufacturers) promotes standards for safety and performance ratings in the refrigeration industry. ASERCOM certification means that a compressor's performance has been determined to meet the specifications stated by its manufacturer.

How It Works

Manufacturer's performance data for a particular compressor model and refrigerant are submitted to ASERCOM for certification. To ensure objectivity, members of the certification committee are selected from competing manufacturers. If the committee agrees with the submitted performance data that model is added to the certified list.

Performance Testing

Models from the certified list are regularly tested to verify performance. To ensure fairness, the compressor to be tested is obtained from a distributor's stock and tested at a competitor's facility. If test results are not up to the listed specifications that model is removed from the certified list.



Frascold stands behind the quality, performance and reliability of all of our products.

We currently have 110 ASERCOM certified models and more on the way.

All of our compressors are run tested at the factory and carry a standard 2 year warranty.

UL CERTIFICATION

Frascold compressors with piston and screw technology are UL certified for the US and CSA certified for Canada. Certification is done according to safety standards UL60335-2, UL60335-1, CAN/CSA-C22.2 and UL684.

Our laboratory, which is accredited and certified by UL, performs the required tests and forwards the reports to UL experts.

The purpose of UL and CSA certifications is to ensure the highest safety standards both as mechanical strength of the body and electrical safety for the installer. In the rare case of electrical failure, the installer is assured of no electrical hazards or risks due to high temperature.

Compressor bodies are rechecked annually to confirm the veracity of the tests performed at the time of certification and the maintenance of quality.



CAPACITY



LEGAL DISCLAIMER: While Frascold has made every effort at the time of publication to ensure the accuracy of the information provided herein, product specifications and performances could be subject to change without notice. You can find the most updated information in our Frascold Selection Software FSS3 at the link: <https://www.frascold.it/en/software>

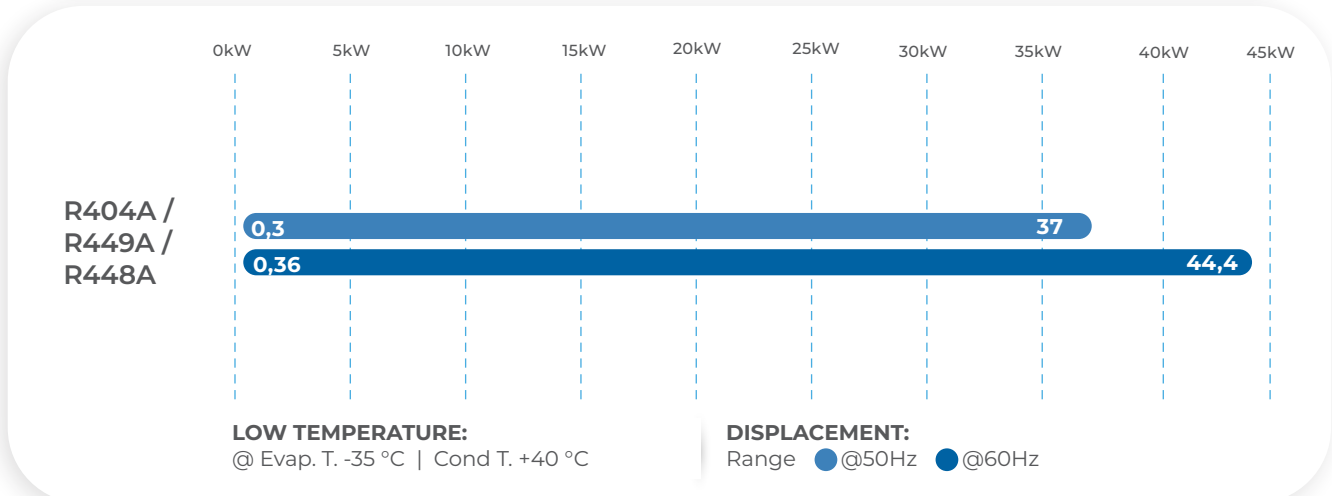
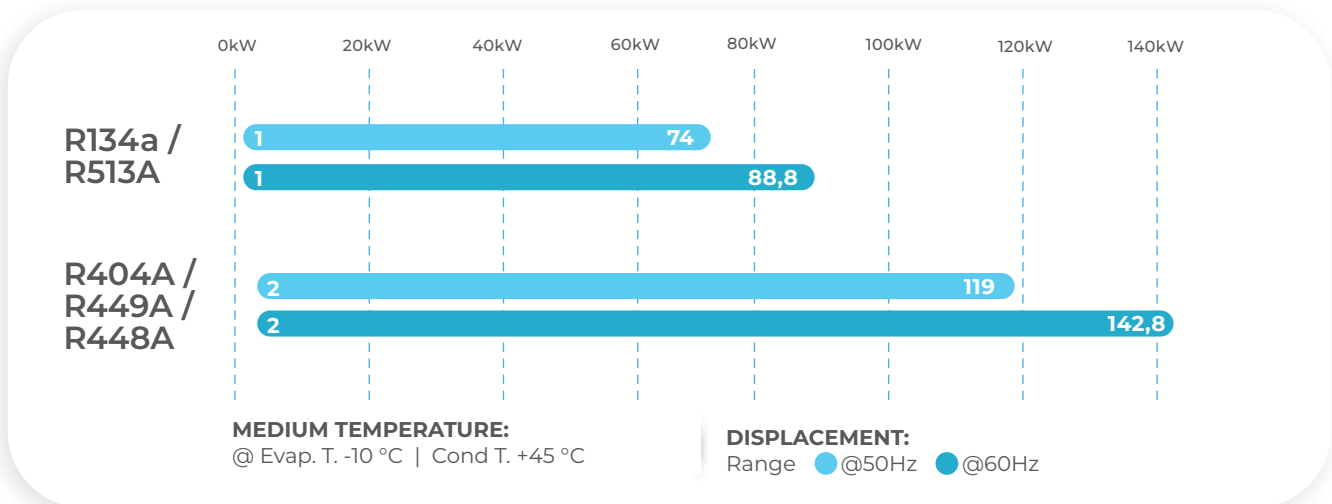
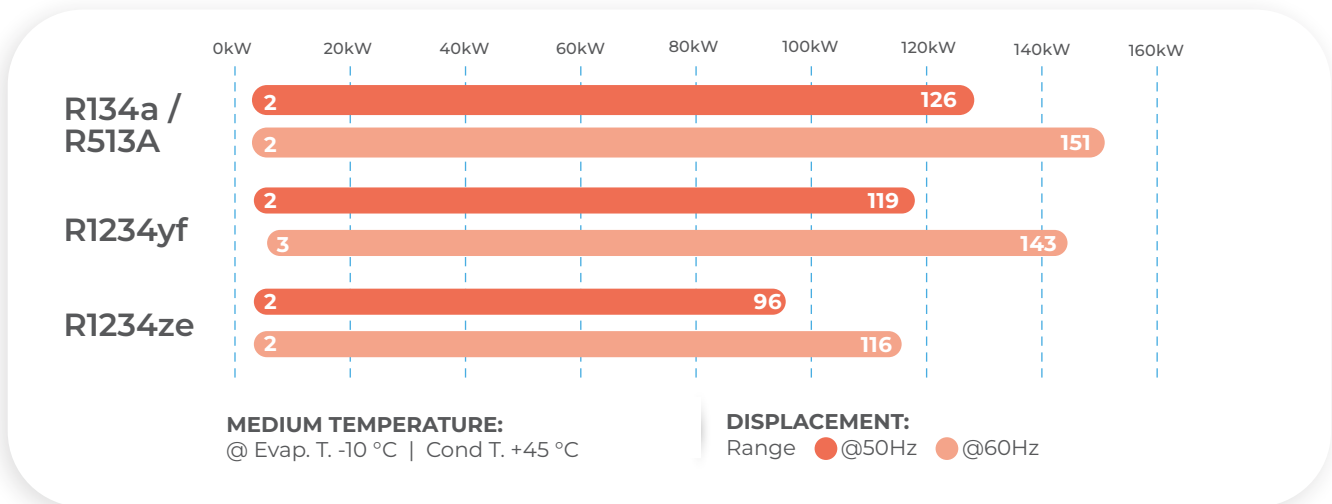

To visualize performance with other refrigerants, contact us or refer to the Frascold Selection Software FSS3: <https://www.frascold.it/software>

PRODUCT RANGE

STANDARD SEMI-HERMETIC RECIPROCATING COMPRESSORS

**A, B, D
SIZES**

2 Cylinders - 22 Models

0.5 - 4 HP
4 - 19 m³/h @50Hz
4 - 22 m³/h @60Hz

**Q, S, V
SIZES**

4 Cylinders - 40 Models

4 - 40 HP
20 - 123 m³/h @50Hz
24 - 148 m³/h @60Hz

**Z
SIZE**

6 Cylinders - 11 Models

25 - 50 HP
106 - 185 m³/h @50Hz
127 - 222 m³/h @60Hz

**W
SIZE**

8 Cylinders - 11 Models

40 - 80 HP
142 - 240 m³/h @50Hz
170 - 288 m³/h @60Hz

MODEL DESIGNATION

Z | 50 | - | 154 | Y

Sizes

A - B - D - Q - S - V - Z - W

Motor Size

From 0,5 to 80 HP

Oil Type

Y | POE (other on request)

H | PAG

Displacement

From 4 to 240 m³/h at 50Hz

INFORMATION PLATE

All the important information to identify the compressor is displayed on the nameplate.
The date of production is contained in the serial number.
The user is responsible for indicating the refrigerant type.

Compressor model

Type **Z50-154Y**

FRASCOLD SPA Nr. **3S001074**

Hz	Displ. m ³ /h	RPM	Max. Operating Disch. Pressure		Max. Static Suct. Pressure	
50	154,38	1450	bar 30		bar 20,5	
60	185,26	1740				

Oil type: POE68 3~ **EAC CE**

Volt		Hz	MRA		LRA	
PWS	YY		PWS	YY	PWS	YY
380-420	380-420	50	90,4	90,4	188,6	321,4
440-480	440-480	60	90,4	90,4	188,6	321,4

 Frascold S.p.A. **Z50154 30S001074** MADE IN ITALY

STANDARD EQUIPMENT AND OPTIONAL ACCESSORIES



Description	Sizes			
	A-B	D	Q-S	V-Z-W
Electric terminal box IP class protection IP56 For Sizes A, B, D, Q, IP54 for Size S, IP66 For Sizes V, Z & W	■	■	■	■
Thermistor	■	■	■	■
Control and protection device (INT69)	■	■	■	
Control, diagnostics & protection device (INT69 Diagnose and INT69 TML Diagnose)	■	■	■	■
Discharge temperature control sensor			■	■
Electronic oil differential pressure switch				■
Reversible oil pump				■
Oil level sight glass (Two for Sizes Q,S,V,Z,& W)	■	■	■	■
Oil charge*	■	■	■	■
Liquid injection connection			■	■
Suction shut-off valve	■	■	■	■
Discharge shut-off valve	■	■	■	■
Nitrogen charge (2bar min)	■	■	■	■
Rubber vibration dampers	■	■	■	■
Crankcase heater	■	■	■	■
US unloader start head			■	■
RSH capacity control head		■	■	■
CC capacity control head			■	■
Head cooling fan	■	■	■	■
Liquid injection kit (FLI)			■	■
Optoelectronic oil level switch				■
Kit adapters for oil equalization line	■	■	■	■
DP-Modbus Gateway	■	■	■	■
Connection cable Modbus Gateway - INT69	■	■	■	■
USB adapter cable	■	■	■	■
Bluetooth module for Diagnose	■	■	■	■

■ Standard
 ■ Optional

*(POE32 For Sizes A, B, D, Q & S, POE68 For Sizes V, Z & W)

CONTROL PROTECTION DEVICE

Discharge Temperature Cutoff

The discharge temperature in certain conditions such as high condensing temperatures, low evaporating pressures or extremely high compression ratios, may reach values that can damage the compressor. All V, Z and W sizes models are supplied with a **safety device** which, in combination with the electronic control module, stops the compressor in the event that the discharge temperature exceeds the set safety limit.

Electronic Safety Device to control lubrication

Frascold compressors in the V, Z and W sizes are supplied complete with an **electronic pressure switch** to control lubrication. It monitors the differential pressure in the lubrication system and stops the compressor in the event of any detected measurement that does not comply with the set safety values. The device is attached directly to the compressor's oil pump and does not require additional fittings.

INT69®

Standard protection equipment on A, B, D, Q and S sizes compressors consists of a chain of PTC or AMS thermistors inserted in the electric motor stator and connected to the **Kriwan INT69®** electronic control module inside the electrical box.

The **INT69®** device is triggered and stops the compressor in the event of thermal overload due to electric motor or mechanical issues.

INT69® Diagnose

Kriwan INT69 TML® Diagnose protection device provides all of the protection of the **INT69®** with advanced diagnostic and communication functions, allowing the compressor to be remotely monitored in real time via modbus-Gateway. System conditions are constantly monitored allowing the compressor to be stopped in the event of incorrect functional parameters and a quick identification of the cause of the malfunction through detailed reports. Stored data allows technicians to accurately and quickly diagnose the past and present state of the cooling system, ensuring fast and cost-effective servicing with short system downtime. **Kriwan INT69® Diagnose** is optional for all models from A to S sizes.

INT69 TML® Diagnose

Kriwan INT69 TML® Diagnose protection device provides all of the protection data logging and remote monitoring capabilities of the **INT69®** and **INT69® Diagnose** but with the addition of lubrication protection. Frascold V, Z and W sizes compressors come standard with **INT69 TML® Diagnose** module.

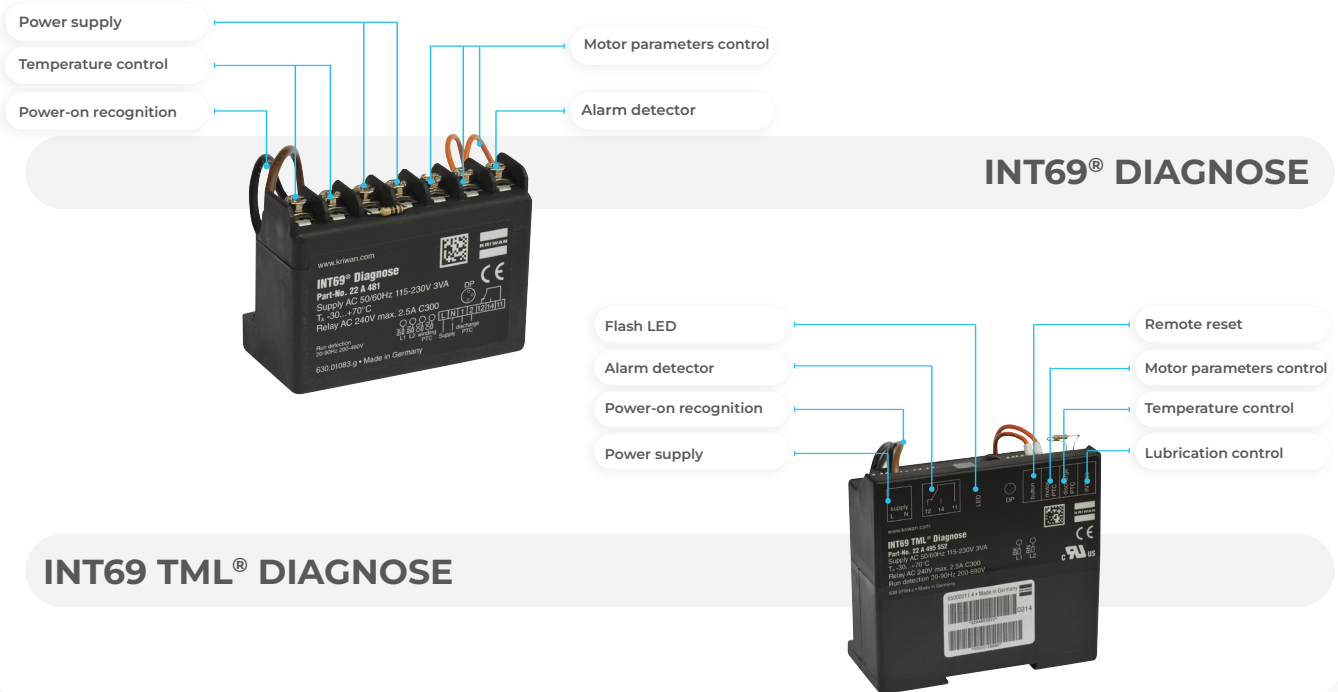

CAPACITY REGULATION

The capacity of standard reciprocating compressors can be regulated with:

1 CAPACITY CONTROL (CC)

2 REDUCED SUCTION HEAD (RSH)

3 VARIABLE FREQUENCY DRIVE (VFD)

1 CAPACITY CONTROL (CC)

Frascold offers a standard capacity control feature. Available on request on 4, 6 and 8-cylinder compressors, capacity may be adjusted by deactivating the heads in order to adapt the cooling capacity of the system to the actual thermal demand. This reduces the number of start-stop cycles and the stress on the compressor mechanics and electric motor. **Possible control stages:**

	4 CYLINDERS	6 CYLINDERS	8 CYLINDERS
2 STEPS	50 / 100%		
2 OR 3 STEPS		66 / 100%	50 / 75 / 100%

2 REDUCED SUCTION HEAD (RSH)

Frascold's patented **Reduced Suction Head (RSH)** unloading technology represents a revolution in capacity control for reciprocating compressors, avoiding problems caused by traditional unloading methods. Reducing to 50% the gas flow of the head, RSH equipped systems:

- Can run **unloaded indefinitely with no additional vibration, heat and stress to the motor** compared to standard unloading methods.
- Match more accurately **fluctuating cooling demand, saving a significant amount of energy** over traditional unloading.

RSH unloading is available exclusively on Frascold's reciprocating compressors (2, 4, 6 and 8 cylinders). RSH equipped systems provide greater application flexibility and significantly reduced energy costs due to the continuous operation of different partialization steps. Fewer start-stop cycles means increased service life, less downtime and lower maintenance costs.

RSH HEADS	2 CYLINDERS	4 CYLINDERS	6 CYLINDERS	8 CYLINDERS
1	50 / 100%	75 / 100%	83 / 100%	87.5 / 100%
2		50 / 75 / 100%	66 / 83 / 100%	75 / 87.5 / 100%
3			50 / 66 / 83 / 100%	62.5 / 75 / 87.5 / 100%
4				50 / 62.5 / 75 / 87.5 / 100%

3 VARIABLE FREQUENCY DRIVE (VFD)

All Frascold standard semi-hermetic reciprocating compressors are designed to be compatible with inverter technology. Inverters, also known as variable frequency drives, can greatly improve performance and efficiency in many applications.

Always check on the Frascold Selection Software FSS3 for capacity data at the various frequencies.

For 400V motors in certain application conditions, there might be a narrowing of the frequency range.

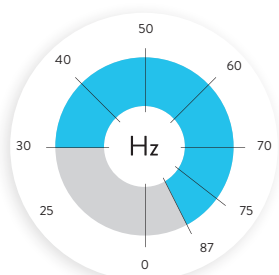

A-B-D Sizes

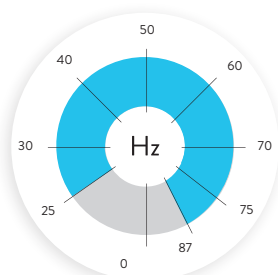

Q-S Sizes

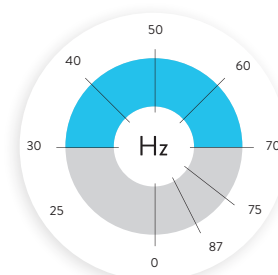

V-Z-W Sizes

● Technical data and operating limits

Motor power supply 220-240V (Δ) - 380-420V (Y) / 3ph / 50Hz | 265-290V (Δ) - 440-480V (Y) / 3ph / 60Hz | DOL connection

Model	Cylinders	Displacement		Oil Charge (3/4 of sightglass)	Motor vers.	Standard		LRA Locked motor current - DOL motor	
		50Hz	60Hz			MRA max operating current		Δ	∩
		m³/h		[l]		Δ	∩	Δ	∩
						[A]		[A]	
A05-4Y	2	3.95	4.74	1	1	4.9	2.8	18.6	10.7
A05-5Y	2	4.93	5.92	1	2	4.7	2.7	18.6	10.7
A07-5Y	2	4.93	5.92	1	1	4.7	2.7	18.6	10.7
A07-6Y	2	5.47	6.56	1	2	4.9	2.8	18.6	10.7
A1-6Y	2	5.47	6.56	1	1	6.2	3.6	23.6	13.6
A1-7Y	2	6.91	8.29	1	2	6.4	3.7	23.6	13.6
A1.5-7Y	2	6.91	8.29	1	1	7.9	4.5	35.8	20.6
A1.5-8Y	2	7.65	9.18	1	1	8.4	4.8	35.8	20.6
B1.5-9.1Y	2	8.96	10.75	1	2	10.2	5.9	46.6	26.8
B1.5-10.1Y	2	9.88	11.86	1	2	9.5	5.5	46.6	26.8
B2-10.1Y	2	9.88	11.86	1	1	11.7	6.7	62.5	35.9
D2-11.1Y	2	11.26	13.51	0.95	1	12.4	7.1	62.5	35.9
D2-13.1Y	2	13.15	15.78	0.95	2	12.4	7.1	62.5	35.9
D3-13.1Y	2	13.15	15.78	0.95	1	15.3	8.8	75.9	43.7
D2-15.1Y	2	15.36	18.43	0.95	2	14.6	8.4	62.5	35.9
D3-15.1Y	2	15.36	18.43	0.95	1	17.6	10.1	75.9	43.7
D3-16.1Y	2	16.4	19.68	0.95	2	17.2	9.9	75.9	43.7
D4-16.1Y	2	16.4	19.68	1.1	1	20.1	11.6	90.3	52
D3-18.1Y	2	17.93	21.52	0.95	2	17.3	10	75.9	43.7
D4-18.1Y	2	17.93	21.52	1.1	1	21.7	12.5	90.3	52
D3-19.1Y	2	19.12	22.94	0.95	2	17	9.8	75.9	43.7
D4-19.1Y	2	19.12	22.94	1.1	1	20.5	11.8	90.3	52
Q4-20.1Y	4	19.77	23.72	1.3	2	17.5	10.1	92.6	53.2
Q4-21.1Y	4	21.18	25.42	1.3	2	17.3	10	92.6	53.2
Q5-21.1Y	4	21.18	25.42	1.3	1	20.1	11.6	110	63.1
Q4-24.1Y	4	23.91	28.69	1.3	2	20.3	11.7	92.6	53.2
Q5-24.1Y	4	23.91	28.69	1.3	1	23.9	13.8	110	63.1
Q4-25.1Y	4	24.69	29.63	1.3	2	19.1	11	92.6	53.2
Q5-25.1Y	4	24.69	29.63	1.3	2	22.1	12.7	110	63.1
Q7-25.1Y	4	24.69	29.63	1.3	1	26.8	15.4	152	87.3
Q5-28.1Y	4	28.02	33.62	1.3	2	24.3	14	110	63.1
Q7-28.1Y	4	28.02	33.62	1.3	1	30.7	17.6	152	87.3
Q5-33.1Y	4	32.66	39.19	1.3	2	25	14.4	110	63.1
Q7-33.1Y	4	32.66	39.19	1.3	1	34.7	20	152	87.3
Q7-36.1Y	4	35.86	43.03	1.3	2	33.6	19.4	152	87.3
Q9-36.1Y	4	35.86	43.03	1.3	1	38.6	22.2	168	96.8
Q9-39.1Y	4	38.57	46.28	1.3	2	38.6	22.2	168	96.8
Q10-39.1Y	4	38.57	46.28	1.3	1	41.2	23.7	201	116

Find the most updated information and other supply voltages in our Frascold Selection Software FSS3 at the link: <https://www.frascold.it/en/software>

LEGAL DISCLAIMER:
While Frascold has made every effort at the time of publication to ensure the accuracy of the information provided herein, product specifications and performances could be subject to change without notice. You can find the most updated information in our Frascold Selection Software FSS3 at the link: <https://www.frascold.it/en/software>

● Technical data and operating limits

Motor power supply 380-420V (Y) / 3ph / 50Hz | 440-480V (Y) / 3ph / 60Hz | PWS connection

Model	Cylinders	Displacement		Oil Charge (3/4 of sightglass)	Motor vers.	Standard	LRA Locked rotor current - PWS motor
		50Hz	60Hz			MRA max operating current	
		m ³ /h				[A]	
S5-33Y	4	32.8	39.36	2.9	2	15.9	35.5
S7-33Y	4	32.8	39.36	2.9	1	20.4	47
S8-42Y	4	41.32	49.58	2.9	2	20.3	52.7
S12-42Y	4	41.32	49.58	2.9	1	22.4	59.1
S10-52Y	4	51.5	61.8	2.9	2	24.5	59.1
S15-52Y	4	51.5	61.8	2.9	1	32.4	74.8
S15-56Y	4	56	67.2	2.9	2	30.7	74.8
S20-56Y	4	56	67.2	2.9	1	38.4	87.5
S20-63Y	4	63.2	75.84	2.9	2	33	102
S25-63Y	4	63.2	75.84	2.9	1	39.5	112
V15-59Y	4	58.48	70.18	4	2	31.1	74.8
V20-59Y	4	58.48	70.18	4	1	35.3	107
V15-71Y	4	70.77	84.92	4	2	32.2	74.8
V25-71Y	4	70.77	84.92	4	1	43.5	118
V20-84Y	4	83.81	100.57	4	2	42.6	107
V30-84Y	4	83.81	100.57	4	1	49.2	132.6
V25-93Y	4	93.05	111.66	4	2	52.3	118.3
V32-93Y	4	93.05	111.66	4	1	53.1	144.5
V25-103Y	4	102.9	123.48	4	2	52.3	118.3
V35-103Y	4	102.9	123.48	4	1	61	144.5
V30-112Y	4	112.11	134.53	4	2	56	132.6
V35-112Y	4	112.11	134.53	4	1	67.5	144.5
V30-123Y	4	123.13	147.76	4	2	60.5	132.6
V40-123Y	4	123.13	147.76	4	1	76.5	159.2
Z25-106Y	6	106.16	127.39	3.7	2	53.6	118.3
Z35-106Y	6	106.16	127.39	3.7	1	60.2	144.5
Z30-126Y	6	125.72	150.86	7.2	2	55.7	132.6
Z40-126Y	6	125.72	150.86	7.2	1	71.9	159.2
Z40-140Y	6	139.68	167.62	7.2	2	70	159.2
Z50-140Y	6	139.68	167.62	7.2	1	79.5	188.6
Z40-154Y	6	154.38	185.26	7.2	2	77.9	159.2
Z50-154Y	6	154.38	185.26	7.2	1	90.4	189
Z40-168Y	6	168.16	201.79	7.2	2	77.9	159
Z50-168Y	6	168.16	201.79	7.2	1	90.4	189
Z50-185Y	6	184.7	221.64	7.2	2	90.4	189
w40-142Y	8	141.5	169.8	7.7	1	89.3	215
W40-168Y	8	167.6	201.12	7.7	2	71.4	215
W50-168Y	8	167.6	201.12	7.7	1	94.8	258
W50-187Y	8	186.1	223.32	7.7	2	89.1	258
W60-187Y	8	186.1	223.32	7.7	1	103.5	326
W60-206Y	8	205.8	246.96	7.7	2	98.8	326
W70-206Y	8	205.8	246.96	7.7	1	116.8	390
W70-228Y	8	227.77	273.32	7.7	2	109.5	390
W75-228Y	8	227.77	273.32	7.7	1	128.4	417
W75-240Y	8	239.02	286.82	7.7	2	115.3	417
W80-240Y	8	239.02	286.82	7.7	1	135.7	417

Tolerance ±10% compared to the average value of the motor voltage range. Other voltages are available on request.
To select contactors, cables and fuses, consider the MRA and the maximum absorbed power. Use AC3 category contactors.

Standard Series

OPERATING LIMITS

Diagrams published in this catalogue are to be considered as a general diagram for the full range of semi-hermetic reciprocating compressors. For specific model and refrigerant performance data, please use the FSS3 Frascold Selection Software available for free download at <https://www.frascold.it/software>

Motor 1 - Medium temperature applications

Motor 2 - Low temperature applications

R134a

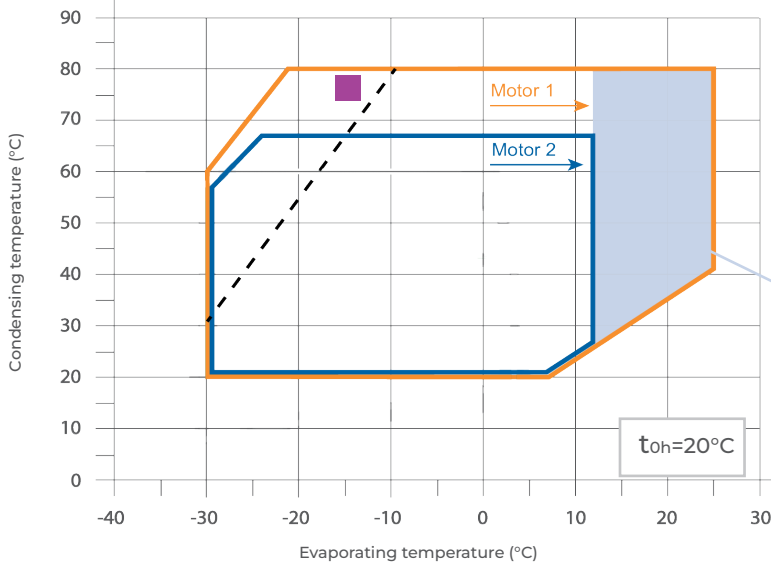

Standard application diagram
Motor size 1 - 2
Compressor capacity 100%
Suction gas temperature 20°C

For operation in this area please contact Frascold

R450A - R513A

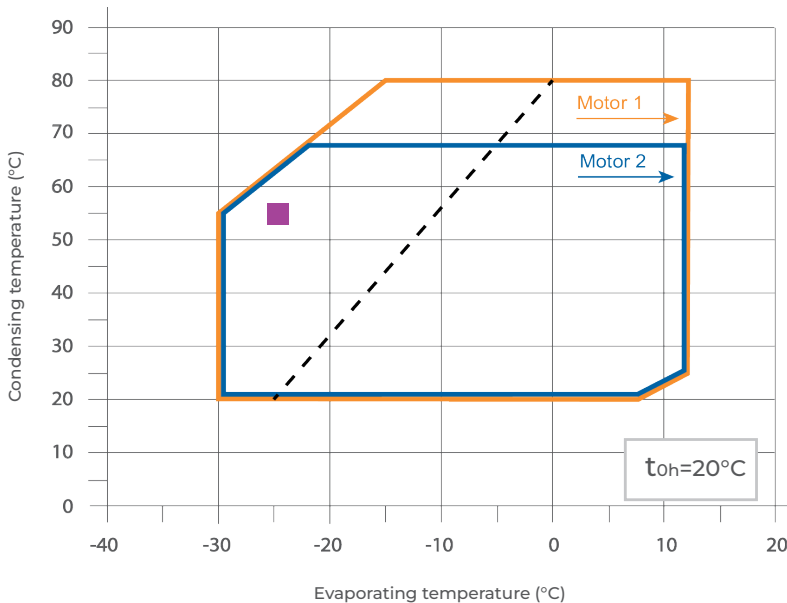

Standard application diagram
Motor size 1 - 2
Compressor capacity 100%
Suction gas temperature 20°C

OPERATING LIMITS

■ For additional cooling or superheat reduction or for performance data on a specific compressor model, please refer to Frascold selection software FSS3

R404A - R507A

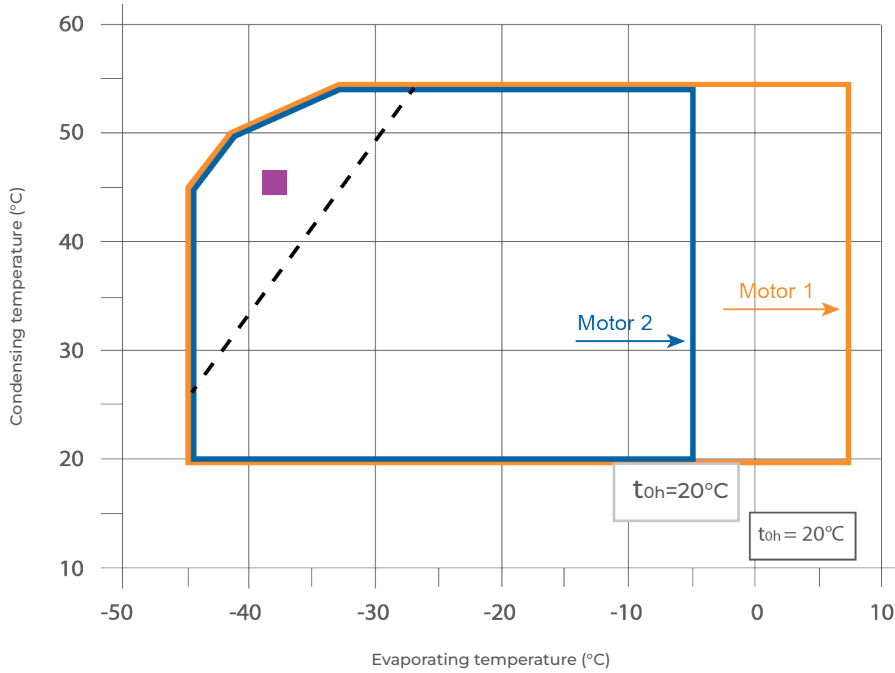

Standard application diagram
 Motor size 1 - 2
 Compressor capacity 100%
 Suction gas temperature 20°C

R448A - R449A

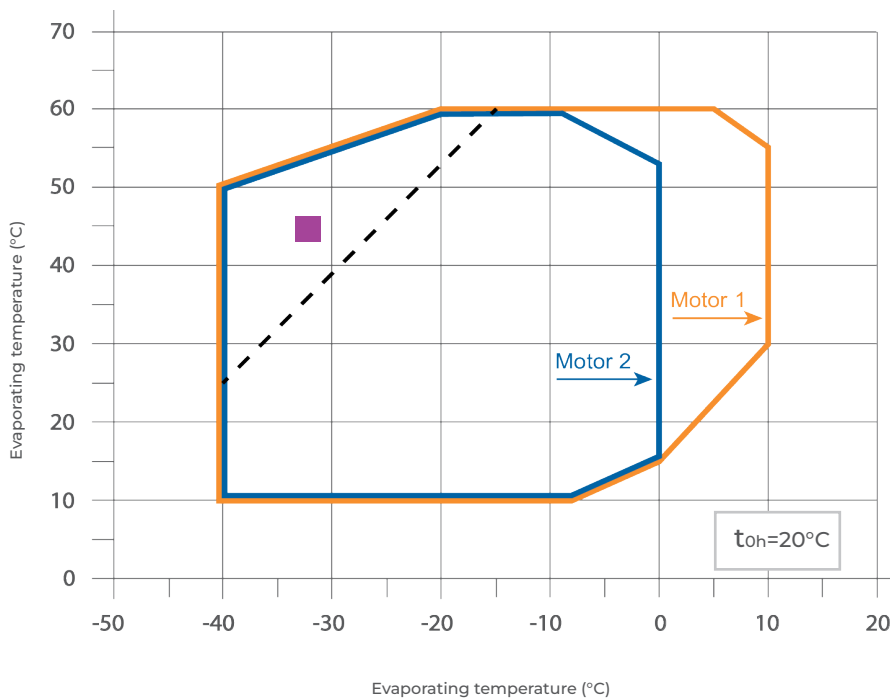

Standard application diagram
 Motor size 1 - 2
 Compressor capacity 100%
 Suction gas temperature 20°C

OPERATING LIMITS



R407F - R407A

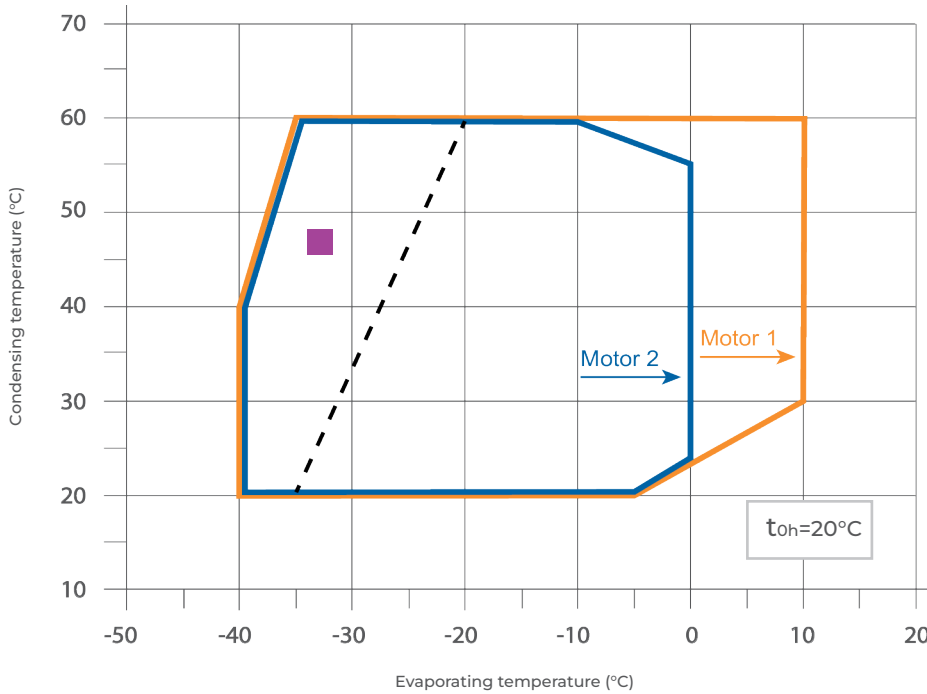

Standard application diagram
Motor size 1 - 2
Compressor capacity 100%
Suction gas temperature 20°C

R407C

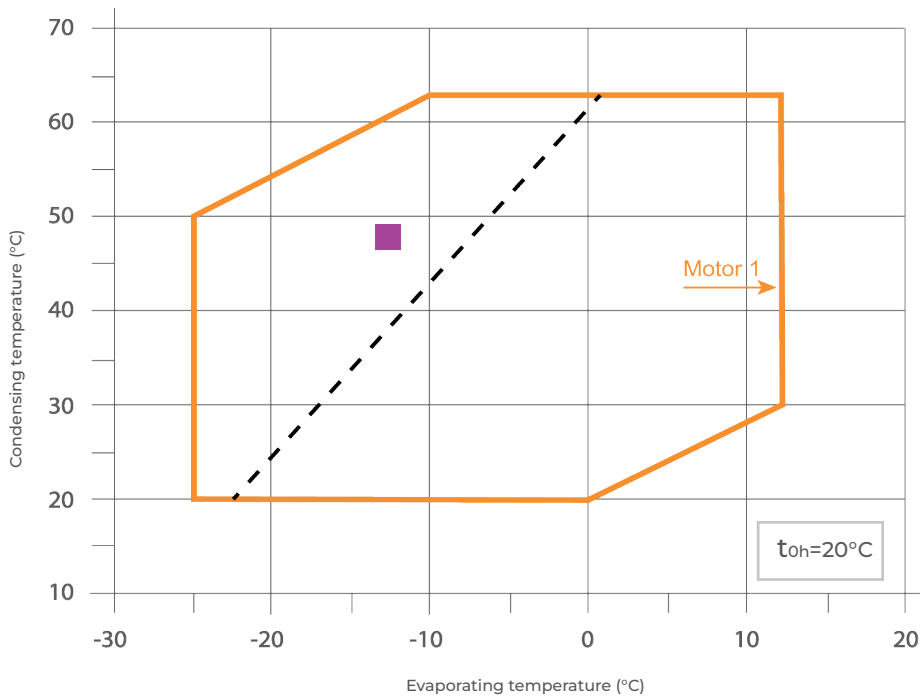

Standard application diagram
Motor size 1 - 2
Compressor capacity 100%
Suction gas temperature 20°C

OPERATING LIMITS



R1234yf

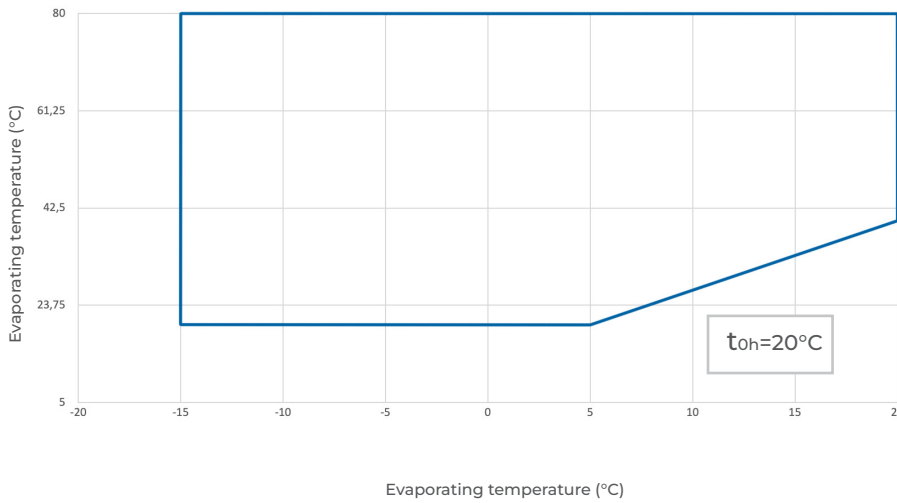

Standard application diagram
Compressor capacity 100%
Suction gas temperature 20°C

R1234ze

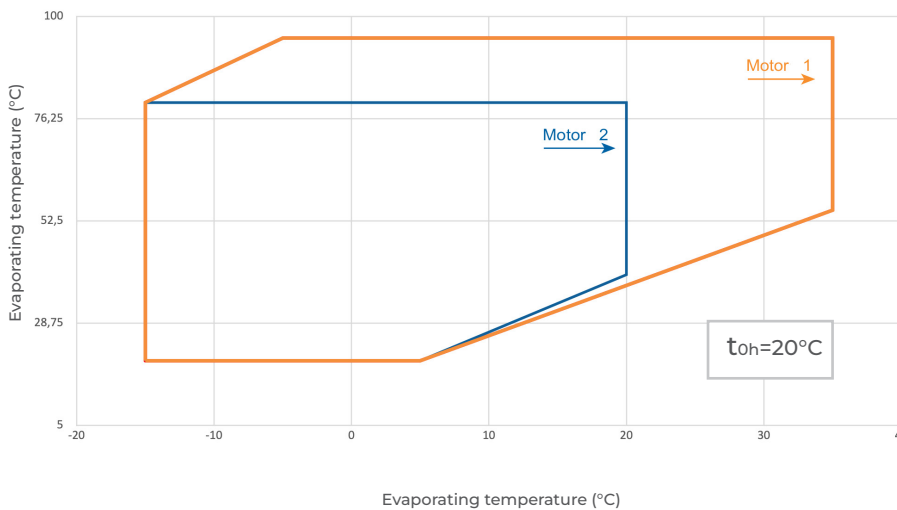

Standard application diagram
Motor size 1 - 2
Compressor capacity 100%
Suction gas temperature 20°C

LEGAL DISCLAIMER:

While Frascold has made every effort at the time of publication to ensure the accuracy of the information provided herein, product specifications and performances could be subject to change without notice. You can find the most updated information in our Frascold Selection Software FSS3 at the link: <https://www.frascold.it/en/software>

TECHNICAL DRAWINGS AND DIMENSIONS

A Size

	Compressor					Valves position						Valves				Net weight
	Lenght	Width	Height	Base mounting		Suction			Discharge			Suction		Discharge		
	A	B	C	D	E	F	G	H	L	M	N	∅	∅			
	[mm]					[mm]						[inch]	[mm]	[inch]	[mm]	
A05-4Y																
A05-5Y																
A07-5Y																
A07-6Y																
A1-6Y	317	237	275	234	194	150	209	29	97	167	18	5/8"	15,8	1/2"	12,7	36
A1-7Y																
A1.5-7Y																
A1.5-8Y																

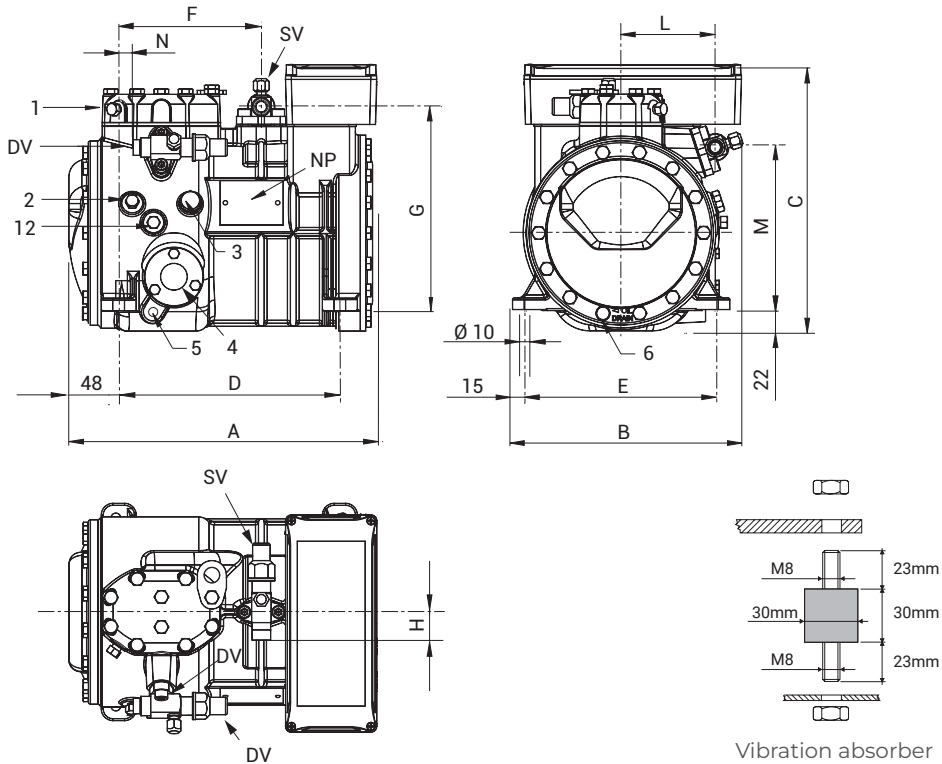

1	High pressure plug	1/8" NPT
2	Low pressure plug	1/8" NPT
3	Oil charge plug	1/4" GAS
4	Oil level sight glass	
5	Crankcase heater socket	
6	Oil drain plug	M8 x 22
12	Oil return plug	1/8" NPT
DV	Discharge valve	
SV	Suction valve	
NP	Nameplate	

	Compressor					Valves position						Valves				Net weight [Kg]
	Lenght	Width	Height	Base mounting		Suction			Discharge			Suction		Discharge		
	A	B	C	D	E	F	G	H	L	M	N	∅	∅			
	[mm]					[mm]						[inch]	[mm]	[inch]	[mm]	
B1.5-9.1Y	329	237	292	234	194	150	209	29	97	167	18	5/8"	15,8	1/2"	12,7	38
B1.5-10.1Y												3/4"	19	5/8"	15,8	
B2-10.1Y	334	237	292	234	194	150	209	31	97	167	18	3/4"	19	5/8"	15,8	40

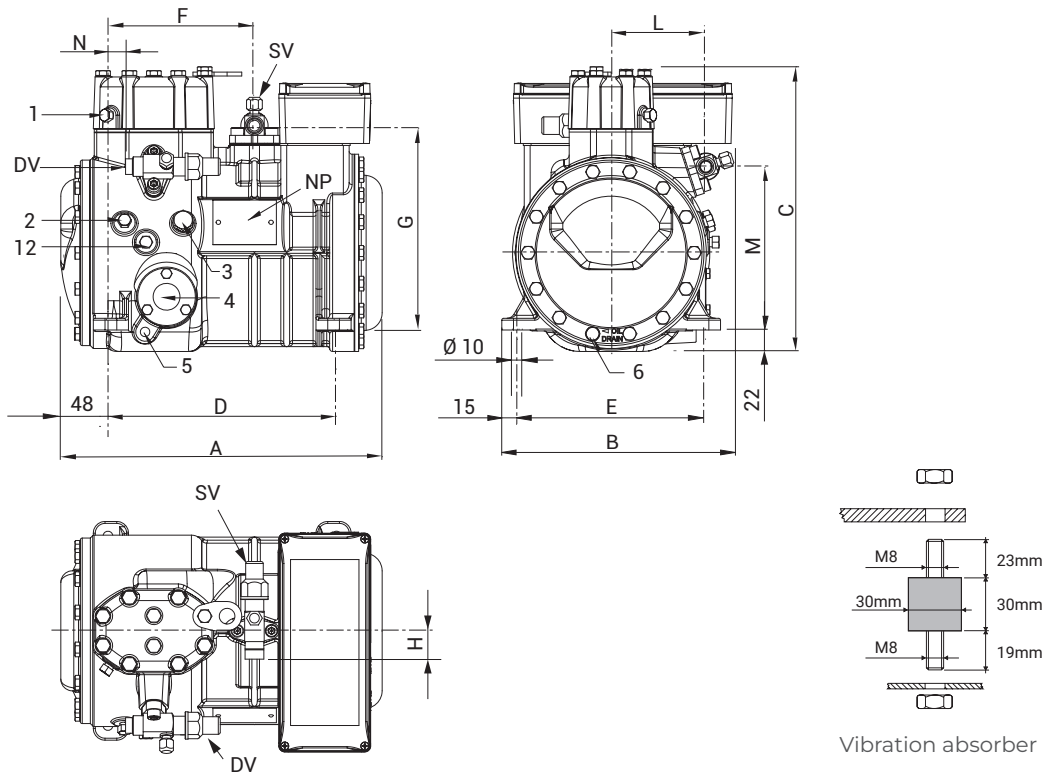

1	High pressure plug	1/8" NPT
2	Low pressure plug	1/8" NPT
3	Oil charge plug	1/4" GAS
4	Oil level sight glass	
5	Crankcase heater socket	
6	Oil drain plug	M8 x 22
12	Oil return plug	1/8" NPT
DV	Discharge valve	
SV	Suction valve	
NP	Nameplate	

	Compressor					Valves position						Valves				Net weight [Kg]	
	Lenght		Width	Height	Base mounting		Suction			Discharge			Suction		Discharge		
	A	B	C	D	E	F	G	H	L	M	N	Ø		Ø			
	[mm]					[mm]						[inch]	[mm]	[inch]	[mm]		
D2-11.1Y*	369	242	295	234	194	165	221	42	94	192	13	7/8"	22,2	5/8"	15,8	45	
D2-13.1Y*	369	242	295	234	194	165	221	42	94	192	13	7/8"	22,2	5/8"	15,8	45	
D3-13.1Y	374	242	317	234	194	165	225	53	94	192	13	1 1/8"	28,6	5/8"	15,8	49	
D2-15.1Y*	369	242	294	234	194	165	221	42	94	192	13	7/8"	22,2	5/8"	15,8	45	
D3-15.1Y	374	242	317	234	194	165	225	53	94	192	13	1 1/8"	28,6	5/8"	15,8	49	
D3-16.1Y	374	242	317	234	194	165	225	53	94	192	13	1 1/8"	28,6	5/8"	15,8	49	
D4-16.1Y	401	242	317	234	194	165	225	53	94	192	5	1 1/8"	28,6	3/4"	19	55	
D3-18.1Y	374	242	317	234	194	165	225	53	94	192	13	1 1/8"	28,6	5/8"	15,8	55	
D4-18.1Y	401	242	317	234	194	165	225	53	94	192	5	1 1/8"	28,6	3/4"	19	55	
D3-19.1Y	374	242	317	234	194	165	225	53	94	192	13	1 1/8"	28,6	5/8"	15,8	49	
D4-19.1Y	401	242	317	234	194	165	225	53	94	192	5	1 1/8"	28,6	3/4"	19	55	

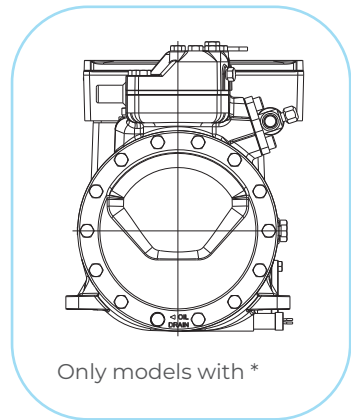
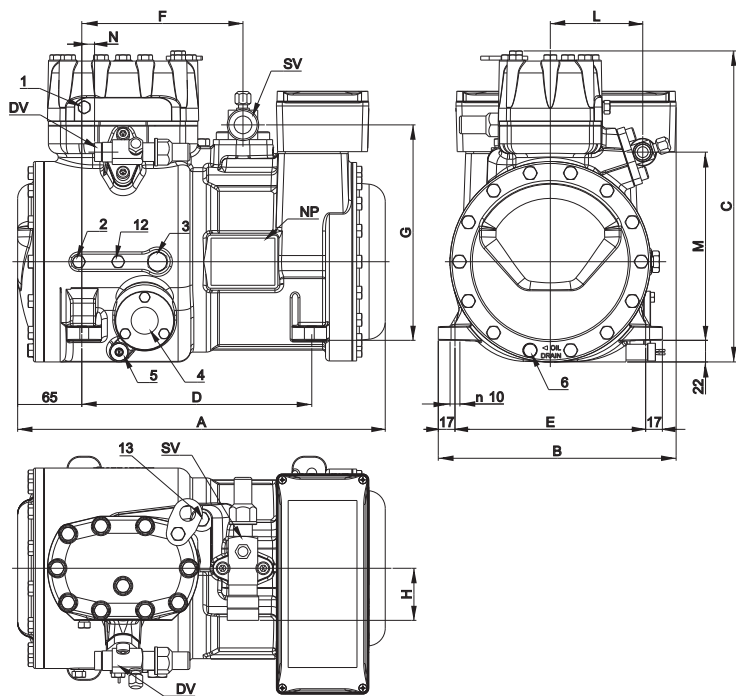

Only models with *

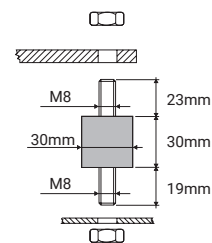

Vibration absorber

1	High pressure plug	1/8" NPT
2	Low pressure plug	1/8" NPT
3	Oil charge plug	1/4" GAS
4	Oil level sight glass	
5	Crankcase heater socket	
6	Oil drain plug	M8 x 22
12	Oil return plug	1/8" NPT
13	Liquid injection plug	
DV	Discharge valve	
SV	Suction valve	
NP	Nameplate	

	Compressor					Valves position						Valves				Net weight [Kg]	
	Lenght		Width	Height	Base mounting		Suction			Discharge			Suction		Discharge		
	A	B	C	D	E	F	G	H	L	M	N	Ø		Ø			
	[mm]					[mm]						[inch]	[mm]	[inch]	[mm]		
Q4-20.1Y	449	286	325	312	246	203	257	53	123	239	12	1 1/8"	28,6	3/4"	19	74	
Q4-21.1Y																	
Q5-21.1Y	449	286	325	312	246	203	257	53	123	239	12	1 1/8"	28,6	3/4"	19	79	
Q4-24.1Y																	
Q5-24.1Y	449	286	325	312	246	203	257	53	123	239	17	1 1/8"	28,6	7/8"	22,2	79	
Q4-25.1Y	449	286	325	312	246	203	257	53	123	239	12	1 1/8"	28,6	3/4"	19	77	
Q5-25.1Y	449	286	325	312	246	203	257	53	123	239	17	1 1/8"	28,6	7/8"	22,2	79	
Q7-25.1Y																	
Q5-28.1Y	449	286	325	312	246	203	261	58	123	239	17	1 3/8"	35	7/8"	22,2	79	
Q7-28.1Y																	
Q5-33.1Y	449	286	328	312	246	203	261	58	123	239	28	1 3/8"	35	1 1/8"	28,6	79	
Q7-33.1Y																	
Q7-36.1Y																	
Q9-36.1Y	464	286	328	312	246	203	261	58	123	239	28	1 3/8"	35	1 1/8"	28,6	83	
Q9-39.1Y																	
Q10-39.1Y	480	286	328	312	246	203	261	58	123	239	28	1 3/8"	35	1 1/8"	28,6	88	

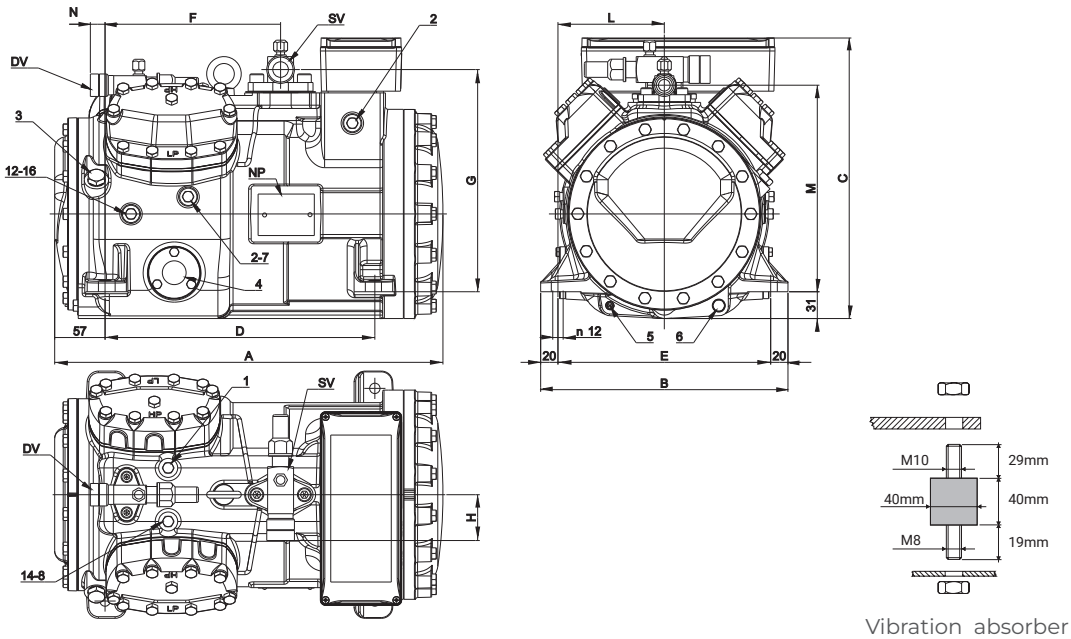

1	High pressure plug	1/8" NPT
2	Low pressure plug	1/8" NPT
3	Oil charge plug	1/4" GAS
4	Oil level sight glass	
5	Crankcase heater socket	
6	Oil drain plug	M8 x 22
7	Liquid injection valve plug	1/8" NPT
8	Liquid injection sensor plug	1/8" NPT
12	Oil return plug	1/8" NPT
14	Max discharge temperature sensor	1/8" NPT
16	Crankcase pressure plug	1/8" NPT
DV	Discharge valve	
SV	Suction valve	
NP	Nameplate	

	Compressor					Valves position						Valves				Net weight [Kg]
	Lenght	Width	Height	Base mounting		Suction			Discharge			Suction		Discharge		
				A	B	C	D	E	F	G	H	L	M	N	∅	
	[mm]					[mm]						[inch]	[mm]	[inch]	[mm]	
S5-33Y	550	405	405	292	266	147	115	58	133	298	23	1 3/8"	35	1 1/8"	28,6	115
S7-33Y S8-42Y	550	405	405	292	266	147	115	58	133	298	23	1 3/8"	35	1 1/8"	28,6	117
S12-42Y S10-52Y	550	405	405	292	266	147	115	58	133	298	23	1 3/8"	35	1 1/8"	28,6	120
S15-52Y	550	405	405	292	266	147	115	61	133	298	23	1 5/8"	42	1 1/8"	28,6	126
S15-56Y	550	405	405	292	266	147	115	61	133	298	23	1 5/8"	42	1 1/8"	28,6	130
S20-56Y	550	405	405	292	266	147	115	61	133	298	23	1 5/8"	42	1 1/8"	28,6	132

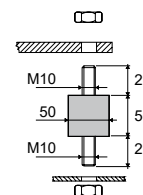
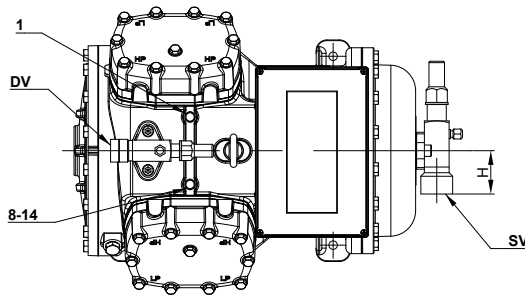
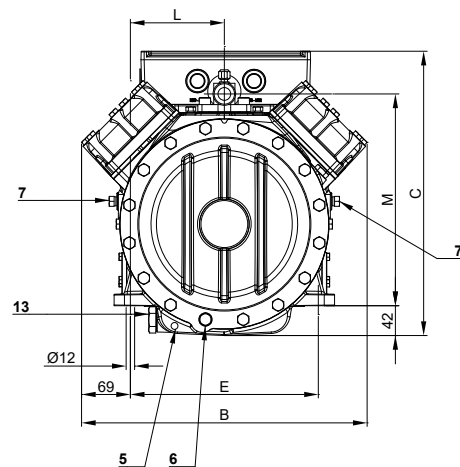
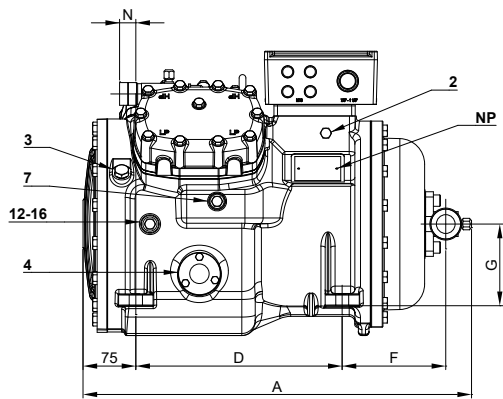

Vibration absorber

1	High pressure plug	1/8" NPT
2	Low pressure plug	1/4" NPT
3	Oil charge plug	1/4" GAS
4	Oil level sight glass	
5	Crankcase heater socket	
6	Oil drain plug	M10 x 30
7	Liquid injection valve plug	1/4" NPT
8	Liquid injection sensor plug	1/8" NPT
12	Oil return plug	1/4" NPT
13	Magnetic plug	1/2" GAS
14	Max discharge temperature sensor	1/8" NPT
16	Crankcase pressure plug	1/4" NPT
DV	Discharge valve	
SV	Suction valve	
NP	Nameplate	

	Compressor					Valves position						Valves				Net weight [Kg]	
	Lenght		Width	Height	Base mounting		Suction			Discharge			Suction		Discharge		
	A	B	C	D	E	F	G	H	L	M	N	∅		∅			
	[mm]					[mm]						[inch]	[mm]	[inch]	[mm]		
S20-63Y	625	405	401	292	266	216	115	69	133	298	23	1 5/8"	42	1 1/8"	28,6	137	
S25-63Y	625	405	401	292	266	216	115	69	133	298	23	1 5/8"	42	1 1/8"	28,6	139	

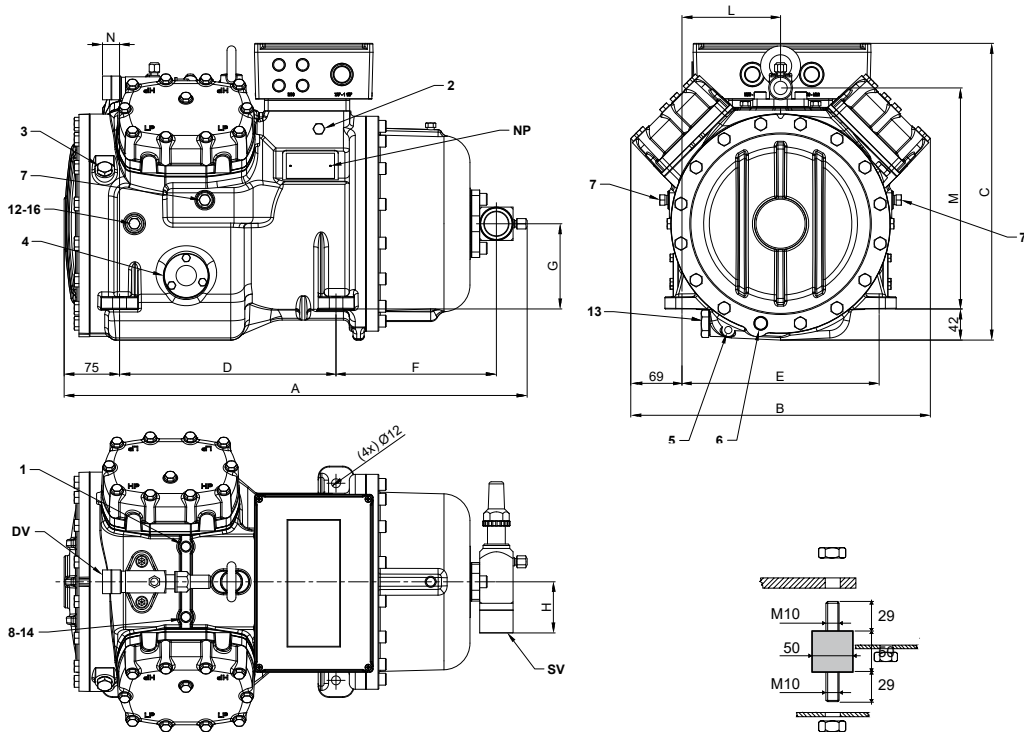

Vibration absorber

1	High pressure plug	1/8" NPT
2	Low pressure plug	1/8" NPT
3	Oil charge plug	1/4" GAS
4	Oil level sight glass	
5	Crankcase heater socket	
6	Oil drain plug	M10 x 30
7	Liquid injection valve plug	1/4" NPT
8	Liquid injection sensor plug	1/8" NPT
12	Oil return plug	1/4" NPT
13	Magnetic plug	1/2" GAS
14	Max discharge temperature sensor	1/8" NPT
16	Crankcase pressure plug	1/4" NPT
DV	Discharge valve	
SV	Suction valve	
NP	Nameplate	

	Compressor					Valves position						Valves				Net weight [Kg]
	Length	Width	Height	Base mounting		Suction			Discharge			Suction		Discharge		
	A	B	C	D	E	F	G	H	L	M	N	∅		∅		
	[mm]					[mm]						[inch]	[mm]	[inch]	[mm]	
V15-59Y	672	460	463	381	305	120	367	95	152	352	43	1 5/8"	42	1 1/8"	28,6	170
V20-59Y	672	460	463	381	305	120	367	95	152	352	43	1 5/8"	42	1 1/8"	28,6	174
V15-71Y	672	460	463	381	305	120	367	95	152	352	43	1 5/8"	42	1 1/8"	28,6	170
V25-71Y	703	460	463	381	305	133	389	130	152	352	48	2 1/8"	54	1 1/8"	35	184
V20-84Y	672	460	463	381	305	120	367	95	152	352	43	1 5/8"	42	1 1/8"	28,6	180
V30-84Y	703	460	463	381	305	133	389	130	152	352	48	2 1/8"	54	1 3/8"	35	187
V25-93Y	703	460	463	381	305	133	389	130	152	352	48	2 1/8"	54	1 3/8"	35	190
V32-93Y	743	460	463	381	305	158	389	130	152	352	48	2 1/8"	54	1 3/8"	35	192
V25-103Y	703	460	463	381	305	133	389	130	152	352	48	2 1/8"	54	1 3/8"	35	190
V35-103Y	743	460	463	381	305	158	389	130	152	352	48	2 1/8"	54	1 3/8"	35	192
V30-112Y	743	460	463	381	305	158	389	130	152	352	48	2 1/8"	54	1 3/8"	35	190
V35-112Y	743	460	463	381	305	158	389	130	152	352	48	2 1/8"	54	1 3/8"	35	193
V30-123Y	743	460	463	381	305	158	389	130	152	352	48	2 1/8"	54	1 3/8"	35	190
V40-123Y	743	460	463	381	305	158	389	130	152	352	48	2 1/8"	54	1 3/8"	35	199

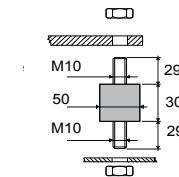
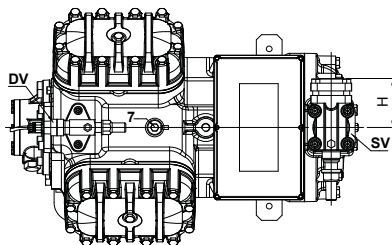
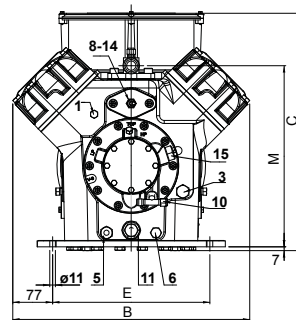
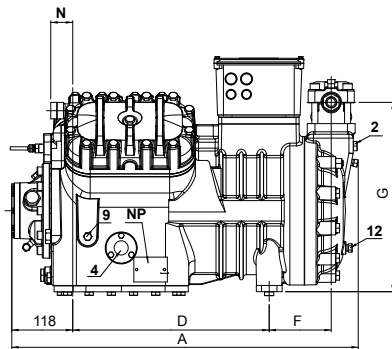

Vibration absorber

1	High pressure plug	1/8" NPT
2	Low pressure plug	1/4" NPT
3	Oil charge plug	3/8" GAS
4	Oil level sight glass	
5	Crankcase heater socket	
6	Oil drain plug	1/4" GAS
7	Liquid injection valve plug	1/4" NPT
8	Liquid injection sensor plug	1/8" NPT
9	Oil pressure switch connection (LP)	1/4" NPT
10	Oil pressure switch connection (HP)	1/4" SAE
11	Oil filter	3/8" GAS
12	Oil return plug	1/4" NPT
14	Max discharge temperature sensor	1/8" NPT
15	Electronic oil pressure switch connection	3/4" UNF
DV	Discharge valve	
SV	Suction valve	
NP	Nameplate	

	Compressor					Valves position						Valves				Net weight [Kg]												
	Lenght		Width	Height	Base mounting		Suction			Discharge			Suction		Discharge													
	A	B	C	D	E	F	G	H	L	M	N	∅	∅	∅	∅													
																[mm]	[mm]	[mm]	[mm]	[mm]	[mm]	[mm]	[mm]	[inch]	[mm]	[inch]	[mm]	[Kg]
Z25-106Y	765	509	457	381	305	155	386	130	123	274	42	2 1/8"	54	1 3/8"	35	220												
Z35-106Y	806	509	457	381	305	180	386	130	123	274	42	2 1/8"	54	1 3/8"	35	223												

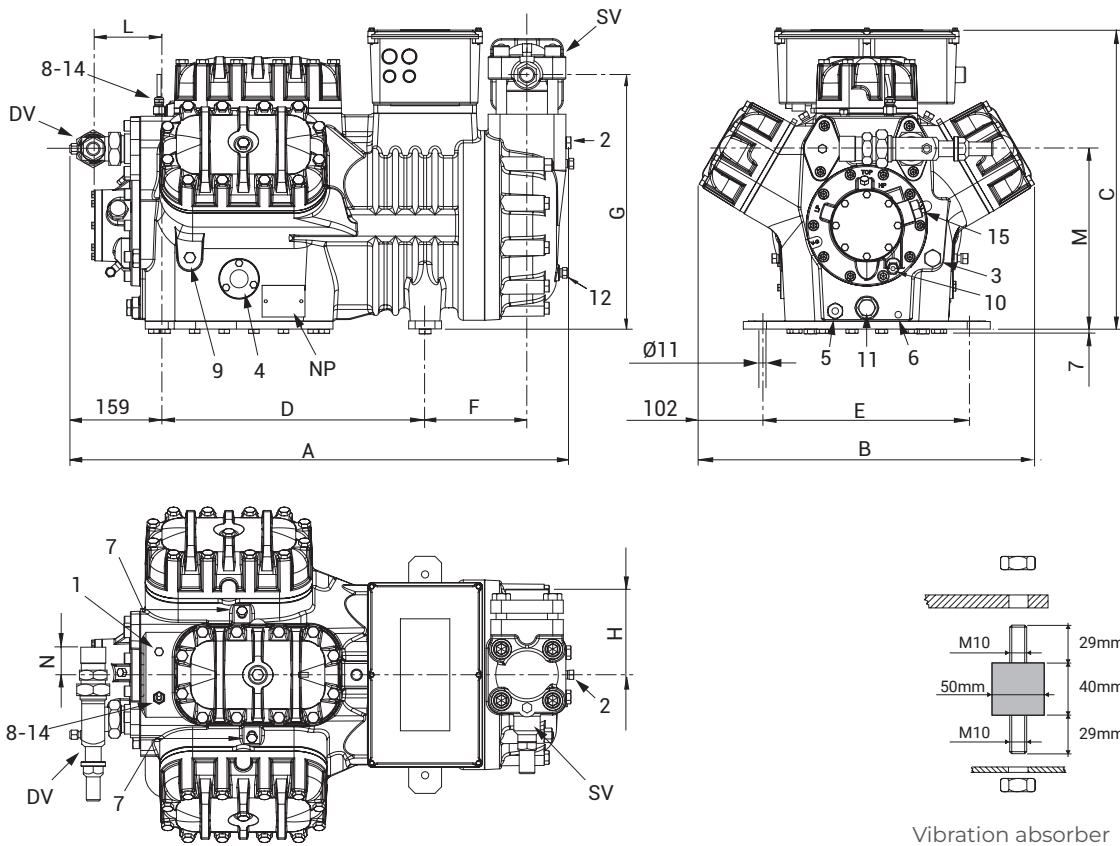

1	High pressure plug	1/8" NPT
2	Low pressure plug	1/4" NPT
3	Oil charge plug	3/8" GAS
4	Oil level sight glass	
5	Crankcase heater socket	
6	Oil drain plug	1/4" GAS
7	Liquid injection valve plug	1/8" NPT
8	Liquid injection sensor plug	1/8" NPT
9	Oil pressure switch connection (LP)	1/4" NPT
10	Oil pressure switch connection (HP)	1/4" SAE
11	Oil filter	3/8" GAS
12	Oil return plug	1/4" NPT
14	Max discharge temperature sensor	1/8" NPT
15	Electronic oil pressure switch connection	3/4" UNF
DV	Discharge valve	
SV	Suction valve	
NP	Nameplate	

	Compressor					Valves position						Valves				Net weight [Kg]
	Length	Width	Height	Base mounting		Suction			Discharge			Suction		Discharge		
				A	B	F	G	H	L	M	N	∅	∅			
	[mm]					[mm]						[inch]	[mm]	[inch]	[mm]	
Z30-126Y	765	509	536	381	305	155	433	130	123	321	42	2 1/8"	54	1 3/8"	35	229
Z40-126Y	806	509	536	381	305	180	433	130	123	321	42	2 5/8"	67	1 3/8"	42	240

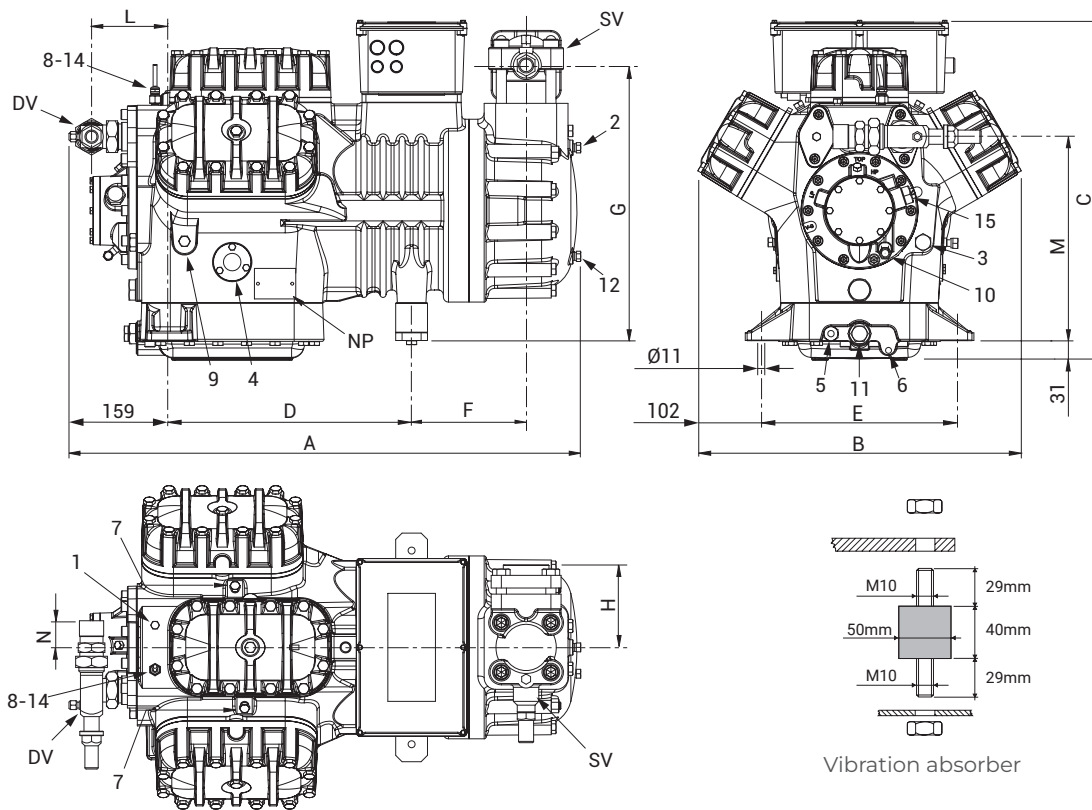

1	High pressure plug	1/8" NPT
2	Low pressure plug	1/4" NPT
3	Oil charge plug	3/8" GAS
4	Oil level sight glass	
5	Crankcase heater socket	
6	Oil drain plug	1/4" GAS
7	Liquid injection valve plug	1/8" NPT
8	Liquid injection sensor plug	1/8" NPT
9	Oil pressure switch connection (LP)	1/4" NPT
10	Oil pressure switch connection (HP)	1/4" SAE
11	Oil filter	3/8" GAS
12	Oil return plug	1/4" NPT
14	Max discharge temperature sensor	1/8" NPT
15	Electronic oil pressure switch connection	3/4" UNF
DV	Discharge valve	
SV	Suction valve	
NP	Nameplate	

	Compressor					Valves position						Valves				Net weight [Kg]
	Length	Width	Height	Base mounting		Suction			Discharge			Suction		Discharge		
	A	B	C	D	E	F	G	H	L	M	N	∅	∅	∅	∅	
	[mm]					[mm]						[inch]	[mm]	[inch]	[mm]	
Z40-140Y	794	509	536	381	305	180	433	130	100	411	95	2 5/8"	67	1 5/8"	42	240
Z50-140Y	794	509	536	381	305	180	433	130	100	411	95	2 5/8"	67	1 5/8"	42	244
Z40-154Y	794	509	536	381	305	180	433	130	100	411	95	2 5/8"	67	1 5/8"	42	240
Z50-154Y	794	509	536	381	305	180	433	130	100	411	95	2 5/8"	67	1 5/8"	42	244
Z40-168Y	794	509	536	381	305	180	433	130	100	411	95	2 5/8"	67	1 5/8"	42	240
Z50-168Y	794	509	536	381	305	180	433	130	100	411	95	2 5/8"	67	1 5/8"	42	244
Z50-185Y																

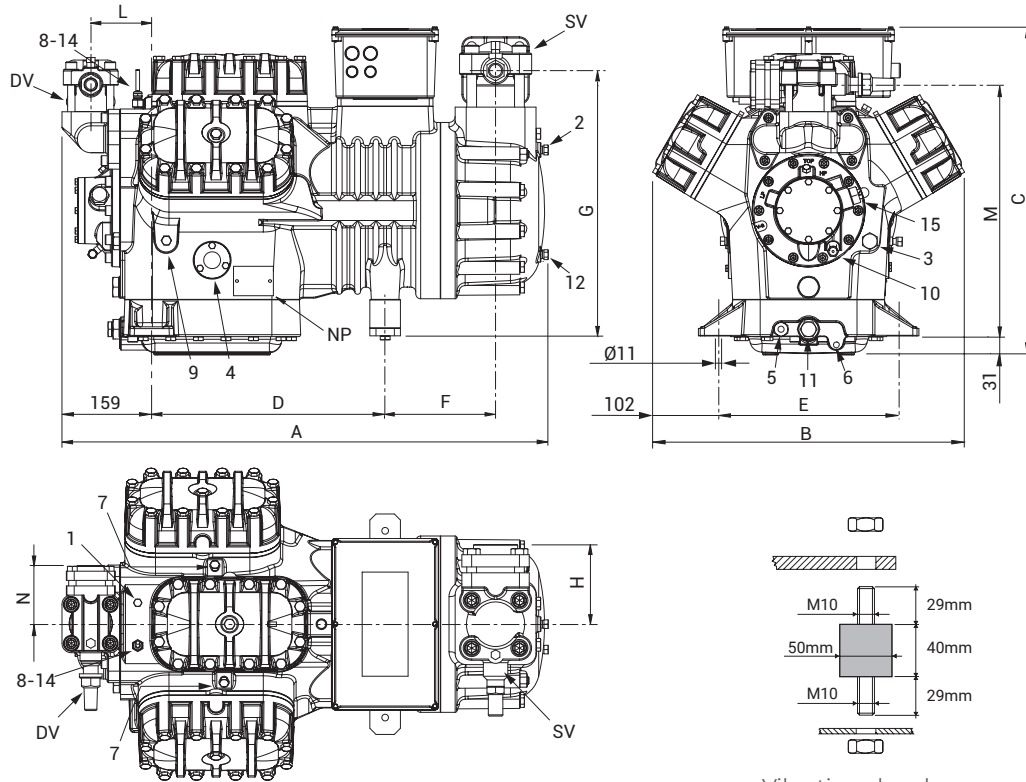

Vibration absorber

1	High pressure plug	1/8" NPT
2	Low pressure plug	1/4" NPT
3	Oil charge plug	3/8" GAS
4	Oil level sight glass	
5	Crankcase heater socket	
6	Oil drain plug	1/4" GAS
7	Liquid injection valve plug	1/8" NPT
8	Liquid injection sensor plug	1/8" NPT
9	Oil pressure switch connection (LP)	1/4" NPT
10	Oil pressure switch connection (HP)	1/4" SAE
11	Oil filter	3/8" GAS
12	Oil return plug	1/4" NPT
14	Max discharge temperature sensor	1/8" NPT
15	Electronic oil pressure switch connection	3/4" UNF
DV	Discharge valve	
SV	Suction valve	
NP	Nameplate	

	Compressor					Valves position						Valves				Net weight [Kg]
	Lenght	Width	Height	Base mounting		Suction			Discharge			Suction		Discharge		
	A	B	C	D	E	F	G	H	L	M	N	∅	∅	∅	∅	
	[mm]					[mm]						[inch]	[mm]	[inch]	[mm]	
W40-142Y	838	511	588	458	305	158	486	160	95	358	95	2 5/8"	67	1 5/8"	42	295
W40-168Y	838	511	588	458	305	158	486	160	95	358	95	2 5/8"	67	1 5/8"	42	299
W50-168Y	838	511	588	458	305	158	486	160	95	358	95	3 1/8"	79,4	1 5/8"	42	305
W50-187Y	838	511	588	458	305	158	486	160	95	358	95	3 1/8"	79,4	1 5/8"	42	311
W60-187Y	838	511	588	458	305	158	486	160	95	358	95	3 1/8"	79,4	1 5/8"	42	315
W60-206Y	838	511	588	458	305	158	486	160	95	358	95	3 1/8"	79,4	2 1/8"	54	320
W70-206Y	864	511	588	458	305	190	486	160	95	358	162	3 1/8"	79,4	2 1/8"	54	328
W70-228Y																
W75-228Y	864	519	588	458	305	190	486	160	95	358	162	3 1/8"	79,4	2 1/8"	54	328
W75-240Y																
W80-240Y																

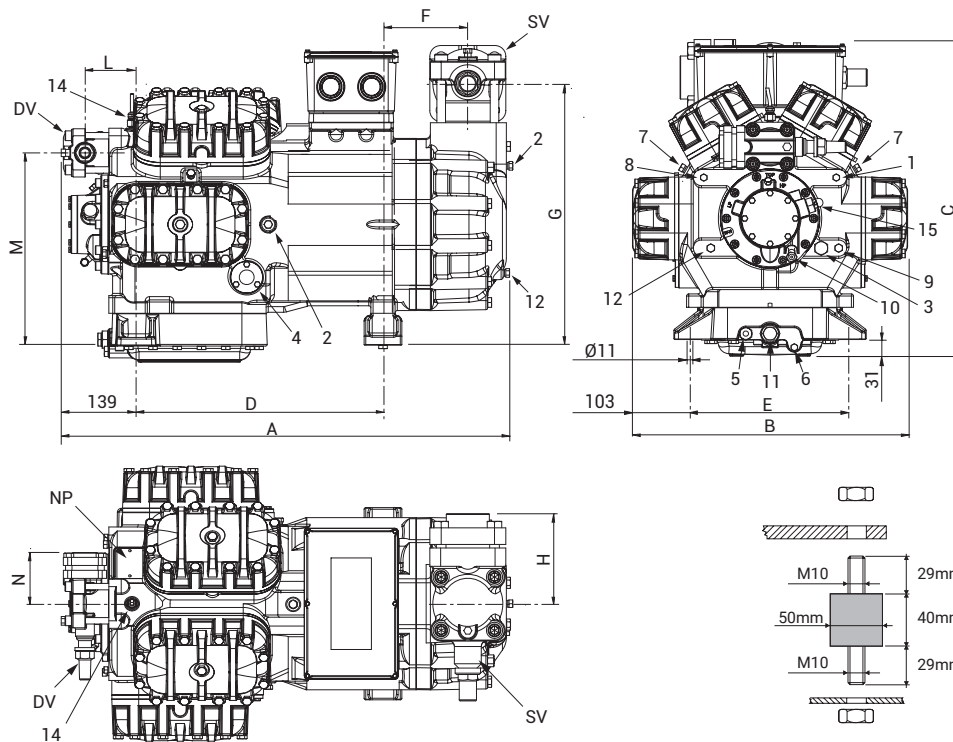

Vibration absorber

1	High pressure plug	1/8" NPT
2	Low pressure plug	1/4" NPT
3	Oil charge plug	3/8" GAS
4	Oil level sight glass	
5	Crankcase heater socket	
6	Oil drain plug	1/4" GAS
7	Liquid injection valve plug	1/8" NPT
8	Liquid injection sensor plug	1/8" NPT
9	Oil pressure switch connection (LP)	1/4" NPT
10	Oil pressure switch connection (HP)	1/4" SAE
11	Oil filter	3/8" GAS
12	Oil return plug	1/4" NPT
14	Max discharge temperature sensor	1/8" NPT
15	Electronic oil pressure switch connection	3/4" UNF
DV	Discharge valve	
SV	Suction valve	
NP	Nameplate	

● Around the world

CONTACT & SUBSIDIARIES



HEADQUARTER & PRODUCTION PLANT

FRASCOLD SPA - ITALY, MILAN

Via B. Melzi 105, 20027 Rescaldina (MI) Italy
Tel. +39 0331 742201 - Fax +39 0331 576102
frascold@frascold.it
www.frascold.it

COMMERCIAL OFFICE

FRASCOLD CHINA

Frascold Refrigeration Co. Ltd
Room 226, Block 3, 2nd floor, Enjoy Wise
Park, No. 909, Tianyaoqiao road,
Xuhui District, Shanghai - China
Ph. +86 021 58650180 / 58650192
frascold.china@frascold.net
www.frascold.net

FRASCOLD USA

5343 Bowden Road, Suite 2
Jacksonville, FL 32216 - USA
Ph. +1 (855) 547 5600 Office
info@frascoldusa.com
www.frascoldusa.com

FRASCOLD INDIA PVT LTD

Frascold India Pvt Ltd.
A1/2/14/15, Gallops Industrial Park,
NH-8A, Sarkhej-Bavla Road, Rajoda,
Ahmedabad 382220 Gujarat - India
Ph: +91 2717 685858
sales@frascoldindia.com
www.frascoldindia.com

FRASCOLD VIETNAM

Frascold Vietnam Co. Ltd
Unit 701, 7th floor, 5 Hoang Van Thai street,
Tan Phu Ward, 07 District,
Ho Chi Minh City - Vietnam
Ph: +84 028 54117375
frascold.china@frascold.net
www.frascold.net

DEDICATED PRODUCTIONS FOR LOCAL MARKETS

CHINA - FVR PRODUCTION PLANT

Frascold refrigeration equipment Co. Ltd
Block 10, Phase 3 of the Standard Building
in the General Free Trade Zone
no. 88 Weichuang road,
Taizhou city of Jiangsu province - China

INDIA - CDU ASSEMBLY PLANT

Frascold India Pvt Ltd.
A1/2/15/16 Gallops Industrial Park,
NH-8A, Sarkhej-Bavla Rd, Rajoda,
Ahmedabad 382220 Gujarat - India





FCAT_100_24_00_EN
03, 2026

We make
temperature

